

1 Specifications

Slim Duct (Home)

Type				SLIM DUCT	SLIM DUCT
Model				AM017KNLDEH/EU	AM022KNLDEH/EU
Power Supply			Φ, #, V, Hz	1,2,220-240,50	1,2,220-240,50
Mode			-	HP/HR	HP/HR
Performance	Capacity (Nominal)	Cooling	kW	1.7	2.2
			Btu/h	5,800	7,500
		Heating	kW	1.9	2.5
			Btu/h	6,500	8,500
Power	Power Input (Nominal)	Cooling	W	28	30
		Heating		28	30
	Current Input (Nominal)	Cooling	A	0.23	0.25
		Heating		0.23	0.25
Fan	Type		-	Sirocco Fan	Sirocco Fan
	Motor	Output x n	W	69 x 1	69 x 1
	Air Flow Rate	H/M/L (UL)	CMM	5.45 / 4.45 / 3.80	6.00 / 4.90 / 3.80
			l/s	90.83 / 74.17 / 63.33	100 / 81.67 / 63.33
	External Static Pressure	Min / Std / Max	mmAq	0.0 / 1.0 / 3.0	0.0 / 1.0 / 3.0
Pa			0.00 / 9.81 / 29.42	0.00 / 9.81 / 29.42	
Piping Connections	Liquid Pipe		Φ, mm	6.35	6.35
			Φ, inch	1/4"	1/4"
	Gas Pipe		Φ, mm	12.70	12.70
			Φ, inch	1/2"	1/2"
Drain Pipe		Φ, mm	VP25 (OD 32, ID 25)	VP25 (OD 32, ID 25)	
Field Wiring	Power Source Wire		mm ²	1.5 ~ 2.5	1.5 ~ 2.5
	Transmission Cable		mm ²	0.75 ~ 1.50	0.75 ~ 1.50
Refrigerant	Type		-	R410A	R410A
	Control Method		-	EEV INCLUDED	EEV INCLUDED
Sound Data	Sound Pressure Level	High / Mid / Low	dB(A)	25 / 22 / 19	26 / 23 / 19
	Sound Power Level	Cooling		40	42
Dimensions	Net Weight		kg	15.3	15.3
	Shipping Weight		kg	18.2	18.2
	Net Dimensions (W×H×D)		mm	700 x 199 x 440	700 x 199 x 440
	Shipping Dimensions (W×H×D)		mm	949 x 280 x 544	949 x 280 x 544
Panel Size	Panel model		-	-	-
	Panel Net Weight		kg	-	-
	Shipping Weight		kg	-	-
	Net Dimensions (W×H×D)		mm	-	-
	Shipping Dimensions (W×H×D)		mm	-	-
Additional Accessories	Drain pump	Drain pump	-	Drain Pump Included	Drain Pump Included
		Max. lifting Height / Displacement	mm / liter/h	750 / 24	750 / 24
	Air Filter		-	Filter Included	Filter Included

NOTE

- 1) Mode : HP(Heat Pump), HR(Heat Recovery)
- 2) Nominal Cooling : Indoor temperature 27°CDB / 19°CWB, Outdoor temperature 35°CDB/24°CWB, Refrigerant pipe length 7.5m, Level difference 0m.
- 3) Nominal Heating : Indoor temperature 20°CDB / 15°CWB, Outdoor temperature 7°CDB / 6°CWB, Refrigerant pipe length 7.5m, Level difference 0m.
- 4) Sound level was acquired in an anechoic room. Thus actual noise level may be different depending on the installation conditions.
- 5) These products contain R410A which is fluorinated greenhouse gas.
- 6) Specifications may be subject to change without prior notice.

* Heat Exchanger type : Fin & Tube (Fin : Al, Tube : Cu)

1 Specifications

Slim Duct (Home)

Type				SLIM DUCT	SLIM DUCT
Model				AM028KNLDEH/EU	AM036KNLDEH/EU
Power Supply			Φ, #, V, Hz	1,2,220-240,50	1,2,220-240,50
Mode			-	HP/HR	HP/HR
Performance	Capacity (Nominal)	Cooling	kW	2.8	3.6
			Btu/h	9,600	12,300
		Heating	kW	3.2	4.0
			Btu/h	10,900	13,600
Power	Power Input (Nominal)	Cooling	W	34	40
		Heating		36	42
	Current Input (Nominal)	Cooling	A	0.28	0.33
		Heating		0.30	0.35
Fan	Type		-	Sirocco Fan	Sirocco Fan
	Motor	Output x n	W	69 x 1	69 x 1
	Air Flow Rate	H/M/L (UL)	CMM	7.05 / 5.15 / 4.35	8.20 / 6.50 / 4.90
			l/s	117.5 / 85.83 / 72.5	136.67 / 108.33 / 81.67
	External Static Pressure	Min / Std / Max	mmAq	0.0 / 1.0 / 3.0	0.0 / 1.0 / 3.0
Pa			0.00 / 9.81 / 29.42	0.00 / 9.81 / 29.42	
Piping Connections	Liquid Pipe		Φ, mm	6.35	6.35
			Φ, inch	1/4"	1/4"
	Gas Pipe		Φ, mm	12.70	12.70
			Φ, inch	1/2"	1/2"
Drain Pipe		Φ, mm	VP25 (OD 32, ID 25)	VP25 (OD 32, ID 25)	
Field Wiring	Power Source Wire		mm ²	1.5 ~ 2.5	1.5 ~ 2.5
	Transmission Cable		mm ²	0.75 ~ 1.50	0.75 ~ 1.50
Refrigerant	Type		-	R410A	R410A
	Control Method		-	EEV INCLUDED	EEV INCLUDED
Sound Data	Sound Pressure Level	High / Mid / Low	dB(A)	28 / 24 / 19	31 / 26 / 20
	Sound Power Level	Cooling		44	46
Dimensions	Net Weight		kg	15.3	15.7
	Shipping Weight		kg	18.2	18.6
	Net Dimensions (W×H×D)		mm	700 x 199 x 440	700 x 199 x 440
	Shipping Dimensions (W×H×D)		mm	949 x 280 x 544	949 x 280 x 544
Panel Size	Panel model		-	-	-
	Panel Net Weight		kg	-	-
	Shipping Weight		kg	-	-
	Net Dimensions (W×H×D)		mm	-	-
	Shipping Dimensions (W×H×D)		mm	-	-
Additional Accessories	Drain pump	Drain pump	-	Drain Pump Included	Drain Pump Included
		Max. lifting Height / Displacement	mm / liter/h	750 / 24	750 / 24
	Air Filter		-	Filter Included	Filter Included

NOTE

- 1) Mode : HP(Heat Pump), HR(Heat Recovery)
 - 2) Nominal Cooling : Indoor temperature 27°CDB / 19°CWB, Outdoor temperature 35°CDB/24°CWB, Refrigerant pipe length 7.5m, Level difference 0m.
 - 3) Nominal Heating : Indoor temperature 20°CDB / 15°CWB, Outdoor temperature 7°CDB / 6°CWB, Refrigerant pipe length 7.5m, Level difference 0m.
 - 4) Sound level was acquired in an anechoic room. Thus actual noise level may be different depending on the installation conditions.
 - 5) These products contain R410A which is fluorinated greenhouse gas.
 - 6) Specifications may be subject to change without prior notice.
- * Heat Exchanger type : Fin & Tube (Fin : Al, Tube : Cu)

1 Specifications

Slim Duct

Type				SLIM DUCT	SLIM DUCT
Model				AM045KNLDEH/EU	AM056KNLDEH/EU
Power Supply			Φ, #, V, Hz	1,2,220-240,50	1,2,220-240,50
Mode			-	HP/HR	HP/HR
Performance	Capacity (Nominal)	Cooling	kW	4.50	5.60
			Btu/h	15,400	19,100
		Heating	kW	5.00	6.30
			Btu/h	17,100	21,500
Power	Power Input (Nominal)	Cooling	W	90.00	95.00
		Heating		90.00	95.00
	Current Input (Nominal)	Cooling	A	0.52	0.53
		Heating		0.52	0.53
Fan	Type		-	Sirocco Fan	Sirocco Fan
	Motor	Output x n	W	-	-
	Air Flow Rate	H/M/L (UL)	CMM	11.00/9.60/8.30	12.00/10.50/9.00
			l/s	183.33/160.00/138.33	200.00/175.00/150.00
	External Static Pressure	Min / Std / Max	mmAq	0.00/2.00/4.00	0.00/2.00/4.00
Pa			0.00/19.61/39.23	0.00/19.61/39.23	
Piping Connections	Liquid Pipe		Φ, mm	6.35	6.35
			Φ, inch	1/4"	1/4"
	Gas Pipe		Φ, mm	12.70	12.70
			Φ, inch	1/2"	1/2"
Drain Pipe		Φ, mm	VP25 (OD 32, ID 25)	VP25 (OD 32, ID 25)	
Field Wiring	Power Source Wire		mm ²	1.5 ~ 2.5	1.5 ~ 2.5
	Transmission Cable		mm ²	0.75 ~ 1.50	0.75 ~ 1.50
Refrigerant	Type		-	R410A	R410A
	Control Method		-	EEV INCLUDED	EEV INCLUDED
Sound Data	Sound Pressure Level	High / Mid / Low	dB(A)	35 / 31 / 26	36 / 34 / 31
	Sound Power Level	Cooling		53	55
Dimensions	Net Weight		kg	24.5	24.5
	Shipping Weight		kg	29.5	29.5
	Net Dimensions (W×H×D)		mm	900 x 199 x 600	900 x 199 x 600
	Shipping Dimensions (W×H×D)		mm	1150 x 280 x 710	1150 x 280 x 710
Panel Size	Panel model		-	-	-
	Panel Net Weight		kg	-	-
	Shipping Weight		kg	-	-
	Net Dimensions (W×H×D)		mm	-	-
	Shipping Dimensions (W×H×D)		mm	-	-
Additional Accessories	Drain pump	Drain pump	-	Drain Pump Included	Drain Pump Included
		Max. lifting Height / Displacement	mm / liter/h	750 / 24	750 / 24
	Air Filter		-	Filter Included	Filter Included

NOTE

- 1) Mode : HP(Heat Pump), HR(Heat Recovery)
 - 2) Nominal Cooling : Indoor temperature 27°CDB / 19°CWB, Outdoor temperature 35°CDB/24°CWB, Refrigerant pipe length 7.5m, Level difference 0m.
 - 3) Nominal Heating : Indoor temperature 20°CDB / 15°CWB, Outdoor temperature 7°CDB / 6°CWB, Refrigerant pipe length 7.5m, Level difference 0m.
 - 4) Sound level was acquired in an anechoic room. Thus actual noise level may be different depending on the installation conditions.
 - 5) These products contain R410A which is fluorinated greenhouse gas.
 - 6) Specifications may be subject to change without prior notice.
- * Heat Exchanger type : Fin & Tube (Fin : Al, Tube : Cu)

1 Specifications

Slim Duct

Type				SLIM DUCT	SLIM DUCT
Model				AM071KNLDEH/EU	AM090KNLDEH/EU
Power Supply			Φ, #, V, Hz	1,2,220-240,50	1,2,220-240,50
Mode			-	HP/HR	HP/HR
Performance	Capacity (Nominal)	Cooling	kW	7.10	9.00
			Btu/h	24,200	30,700
		Heating	kW	8.00	10.00
			Btu/h	27,300	34,100
Power	Power Input (Nominal)	Cooling	W	120.00	170.00
		Heating		120.00	170.00
	Current Input (Nominal)	Cooling	A	0.60	0.96
		Heating		0.60	0.96
Fan	Type		-	Sirocco Fan	Sirocco Fan
	Motor	Output x n	W	-	-
	Air Flow Rate	H/M/L (UL)	CMM	16.50/15.00/13.50	29.00/27.00/25.00
			l/s	275.00/250.00/225.00	483.33/450.00/416.67
	External Static Pressure	Min / Std / Max	mmAq	0.00/2.00/4.00	0.00/3.00/6.00
Pa			0.00/19.61/39.23	0.00/29.42/58.84	
Piping Connections	Liquid Pipe		Φ, mm	9.52	9.52
			Φ, inch	3/8"	3/8"
	Gas Pipe		Φ, mm	15.88	15.88
			Φ, inch	5/8"	5/8"
Drain Pipe		Φ, mm	VP25 (OD 32, ID 25)	VP25 (OD 32, ID 25)	
Field Wiring	Power Source Wire		mm ²	1.5 ~ 2.5	1.5 ~ 2.5
	Transmission Cable		mm ²	0.75 ~ 1.50	0.75 ~ 1.50
Refrigerant	Type		-	R410A	R410A
	Control Method		-	EEV INCLUDED	EEV INCLUDED
Sound Data	Sound Pressure Level	High / Mid / Low	dB(A)	38 / 36 / 33	37 / 36 / 34
	Sound Power Level	Cooling		57	66
Dimensions	Net Weight		kg	30.5	40.5
	Shipping Weight		kg	35.5	48.0
	Net Dimensions (W×H×D)		mm	1100 x 199 x 600	1300 x 295 x 690
	Shipping Dimensions (W×H×D)		mm	1350 x 280 x 710	1575 x 370 x 835
Panel Size	Panel model		-	-	-
	Panel Net Weight		kg	-	-
	Shipping Weight		kg	-	-
	Net Dimensions (W×H×D)		mm	-	-
	Shipping Dimensions (W×H×D)		mm	-	-
Additional Accessories	Drain pump	Drain pump	-	Drain Pump Included	Drain Pump Included
		Max. lifting Height / Displacement	mm / liter/h	750 / 24	750 / 24
	Air Filter		-	Filter Included	Filter Included

NOTE

- 1) Mode : HP(Heat Pump), HR(Heat Recovery)
 - 2) Nominal Cooling : Indoor temperature 27°CDB / 19°CWB, Outdoor temperature 35°CDB/24°CWB, Refrigerant pipe length 7.5m, Level difference 0m.
 - 3) Nominal Heating : Indoor temperature 20°CDB / 15°CWB, Outdoor temperature 7°CDB / 6°CWB, Refrigerant pipe length 7.5m, Level difference 0m.
 - 4) Sound level was acquired in an anechoic room. Thus actual noise level may be different depending on the installation conditions.
 - 5) These products contain R410A which is fluorinated greenhouse gas.
 - 6) Specifications may be subject to change without prior notice.
- * Heat Exchanger type : Fin & Tube (Fin : Al, Tube : Cu)

1 Specifications

Slim Duct

Type				SLIM DUCT	SLIM DUCT	SLIM DUCT
Model				AM112KNLDEH/EU	AM128KNLDEH/EU	AM140KNLDEH/EU
Power Supply			Φ, #, V, Hz	1,2,220-240,50	1,2,220-240,50	1,2,220-240,50
Mode			-	HP/HR	HP/HR	HP/HR
Performance	Capacity (Nominal)	Cooling	kW	11.20	12.80	14.00
			Btu/h	38,200	43,700	47,800
		Heating	kW	12.50	13.80	16.00
			Btu/h	42,700	47,100	54,600
Power	Power Input (Nominal)	Cooling	W	170.00	200.00	220.00
		Heating		170.00	200.00	220.00
	Current Input (Nominal)	Cooling	A	0.96	1.28	1.43
		Heating		0.96	1.28	1.43
Fan	Type		-	Sirocco Fan	Sirocco Fan	Sirocco Fan
	Motor	Output x n	W	-	-	-
	Air Flow Rate	H/M/L (UL)	CMM	31.20/29.00/27.00	34.00/32.00/30.00	36.00/34.00/32.00
			l/s	520.00/483.33/450.00	566.67/533.33/500.00	600.00/566.67/533.33
	External Static Pressure	Min / Std / Max	mmAq	0.00/3.00/6.00	0.00/3.00/6.00	0.00/3.00/6.00
Pa			0.00/29.42/58.84	0.00/29.42/58.84	0.00/29.42/58.84	
Piping Connections	Liquid Pipe		Φ,mm	9.52	9.52	9.52
			Φ, inch	3/8"	3/8"	3/8"
	Gas Pipe		Φ,mm	15.88	15.88	15.88
			Φ, inch	5/8"	5/8"	5/8"
Drain Pipe		Φ,mm	VP25 (OD 32,ID 25)	VP25 (OD 32,ID 25)	VP25 (OD 32,ID 25)	
Field Wiring	Power Source Wire		mm ²	1.5 ~ 2.5	1.5 ~ 2.5	1.5 ~ 2.5
	Transmission Cable		mm ²	0.75 ~ 1.50	0.75 ~ 1.50	0.75 ~ 1.50
Refrigerant	Type		-	R410A	R410A	R410A
	Control Method		-	EEV INCLUDED	EEV INCLUDED	EEV INCLUDED
Sound Data	Sound Pressure Level	High / Mid / Low	dB(A)	37 / 36 / 34	37 / 36 / 34	39 / 38 / 36
	Sound Power Level	Cooling		66	66	68
Dimensions	Net Weight		kg	40.5	42.0	42.0
	Shipping Weight		kg	48.0	49.5	49.5
	Net Dimensions (W×H×D)		mm	1300 x 295 x 690	1300 x 295 x 690	1300 x 295 x 690
	Shipping Dimensions (W×H×D)		mm	1575 x 370 x 835	1575 x 370 x 835	1575 x 370 x 835
Panel Size	Panel model		-	-	-	-
	Panel Net Weight		kg	-	-	-
	Shipping Weight		kg	-	-	-
	Net Dimensions (W×H×D)		mm	-	-	-
	Shipping Dimensions (W×H×D)		mm	-	-	-
Additional Accessories	Drain pump	Drain pump	-	Drain Pump Included	Drain Pump Included	Drain Pump Included
		Max. lifting Height / Displacement	mm / liter/h	750 / 24	750 / 24	750 / 24
	Air Filter		-	Filter Included	Filter Included	Filter Included

NOTE

- 1) Mode : HP(Heat Pump), HR(Heat Recovery)
 - 2) Nominal Cooling : Indoor temperature 27°CDB / 19°CWB, Outdoor temperature 35°CDB/24°CWB, Refrigerant pipe length 7.5m, Level difference 0m.
 - 3) Nominal Heating : Indoor temperature 20°CDB / 15°CWB, Outdoor temperature 7°CDB / 6°CWB, Refrigerant pipe length 7.5m, Level difference 0m.
 - 4) Sound level was acquired in an anechoic room. Thus actual noise level may be different depending on the installation conditions.
 - 5) These products contain R410A which is fluorinated greenhouse gas.
 - 6) Specifications may be subject to change without prior notice.
- * Heat Exchanger type : Fin & Tube (Fin : Al, Tube : Cu)

2 Capacity Table

Slim Duct

Cooling

TC : Total Capacity(kW), SHC : Sensible Heat Capacity(kW)

Capacity Index	Outdoor Air Temp. (°C, DB)	Indoor temperature													
		20(°C, DB)		23(°C, DB)		26(°C, DB)		27(°C, DB)		28(°C, DB)		30(°C, DB)		32(°C, DB)	
		14(°C, WB)		16(°C, WB)		18(°C, WB)		19(°C, WB)		20(°C, WB)		22(°C, WB)		24(°C, WB)	
	TC	SHC	TC	SHC	TC	SHC	TC	SHC	TC	SHC	TC	SHC	TC	SHC	
017	10	1.2	1.0	1.4	1.2	1.6	1.3	1.7	1.3	1.8	1.3	1.9	1.4	2.0	1.2
	12	1.2	1.0	1.4	1.2	1.6	1.3	1.7	1.3	1.8	1.3	1.9	1.4	2.0	1.2
	14	1.2	1.0	1.4	1.2	1.6	1.3	1.7	1.3	1.8	1.3	1.9	1.4	2.0	1.2
	16	1.2	1.0	1.4	1.2	1.6	1.3	1.7	1.3	1.8	1.3	1.9	1.3	2.0	1.2
	18	1.2	1.0	1.4	1.2	1.6	1.3	1.7	1.3	1.8	1.3	1.9	1.3	2.0	1.2
	20	1.2	1.0	1.4	1.2	1.6	1.3	1.7	1.3	1.8	1.3	1.9	1.3	2.0	1.2
	21	1.2	1.0	1.4	1.2	1.6	1.3	1.7	1.3	1.8	1.3	1.9	1.3	2.0	1.2
	23	1.2	1.0	1.4	1.2	1.6	1.3	1.7	1.3	1.8	1.3	1.9	1.3	2.0	1.2
	25	1.2	1.0	1.4	1.2	1.6	1.3	1.7	1.3	1.8	1.3	1.9	1.3	2.0	1.2
	27	1.2	1.0	1.4	1.2	1.6	1.3	1.7	1.3	1.8	1.3	1.9	1.3	2.0	1.2
	29	1.2	1.0	1.4	1.2	1.6	1.3	1.7	1.3	1.8	1.3	1.9	1.3	2.0	1.2
	31	1.2	1.0	1.4	1.2	1.6	1.3	1.7	1.3	1.8	1.3	1.9	1.3	2.0	1.2
	33	1.2	1.0	1.4	1.2	1.6	1.3	1.7	1.3	1.8	1.3	1.9	1.3	2.0	1.2
	35	1.2	1.0	1.4	1.2	1.6	1.3	1.7	1.3	1.8	1.3	1.9	1.3	2.0	1.2
	37	1.2	1.0	1.4	1.2	1.6	1.3	1.7	1.3	1.8	1.3	1.9	1.3	2.0	1.2
39	1.2	1.0	1.4	1.2	1.6	1.3	1.7	1.3	1.8	1.3	1.9	1.3	1.9	1.2	
42	1.2	1.0	1.4	1.2	1.6	1.3	1.7	1.3	1.8	1.3	1.9	1.3	1.9	1.2	
44	1.2	1.0	1.4	1.2	1.5	1.3	1.6	1.2	1.7	1.2	1.8	1.2	1.8	1.1	
46	1.2	1.0	1.4	1.2	1.5	1.2	1.6	1.2	1.7	1.2	1.7	1.2	1.7	1.1	
48	1.2	1.0	1.4	1.2	1.5	1.2	1.5	1.2	1.6	1.2	1.7	1.2	1.7	1.1	
022	10	1.5	1.2	1.8	1.4	2.1	1.6	2.2	1.6	2.3	1.6	2.5	1.7	2.6	1.5
	12	1.5	1.2	1.8	1.4	2.1	1.6	2.2	1.6	2.3	1.6	2.5	1.7	2.6	1.5
	14	1.5	1.2	1.8	1.4	2.1	1.6	2.2	1.6	2.3	1.6	2.5	1.7	2.6	1.5
	16	1.5	1.2	1.8	1.4	2.1	1.6	2.2	1.6	2.3	1.6	2.4	1.6	2.6	1.5
	18	1.5	1.2	1.8	1.4	2.1	1.6	2.2	1.6	2.3	1.6	2.4	1.6	2.6	1.5
	20	1.5	1.2	1.8	1.4	2.1	1.6	2.2	1.6	2.3	1.6	2.4	1.6	2.6	1.5
	21	1.5	1.2	1.8	1.4	2.1	1.6	2.2	1.6	2.3	1.6	2.4	1.6	2.6	1.5
	23	1.5	1.2	1.8	1.4	2.1	1.6	2.2	1.6	2.3	1.6	2.4	1.6	2.6	1.5
	25	1.5	1.2	1.8	1.4	2.1	1.6	2.2	1.6	2.3	1.6	2.4	1.6	2.6	1.5
	27	1.5	1.2	1.8	1.4	2.1	1.6	2.2	1.6	2.3	1.6	2.4	1.6	2.6	1.5
	29	1.5	1.2	1.8	1.4	2.1	1.6	2.2	1.6	2.3	1.6	2.4	1.6	2.6	1.5
	31	1.5	1.2	1.8	1.4	2.1	1.6	2.2	1.6	2.3	1.6	2.4	1.6	2.6	1.5
	33	1.5	1.2	1.8	1.4	2.1	1.6	2.2	1.6	2.3	1.6	2.4	1.6	2.6	1.5
	35	1.5	1.2	1.8	1.4	2.1	1.6	2.2	1.6	2.3	1.6	2.4	1.6	2.6	1.5
	37	1.5	1.2	1.8	1.4	2.1	1.6	2.2	1.6	2.3	1.6	2.4	1.6	2.6	1.5
39	1.5	1.2	1.8	1.4	2.1	1.6	2.2	1.6	2.3	1.6	2.4	1.6	2.5	1.4	
42	1.5	1.2	1.8	1.4	2.1	1.6	2.2	1.6	2.3	1.6	2.4	1.6	2.4	1.4	
44	1.5	1.2	1.8	1.4	2.0	1.5	2.1	1.5	2.2	1.5	2.3	1.5	2.4	1.3	
46	1.5	1.2	1.8	1.4	2.0	1.5	2.0	1.5	2.1	1.5	2.2	1.5	2.3	1.3	
48	1.5	1.2	1.8	1.4	2.0	1.5	2.0	1.4	2.1	1.5	2.1	1.4	2.2	1.2	
028	10	1.9	1.6	2.3	1.8	2.6	1.9	2.8	2.0	2.9	2.0	3.1	2.0	3.4	2.0
	12	1.9	1.6	2.3	1.8	2.6	1.9	2.8	2.0	2.9	2.0	3.1	2.0	3.3	1.9
	14	1.9	1.6	2.3	1.8	2.6	1.9	2.8	2.0	2.9	2.0	3.1	2.0	3.3	1.9
	16	1.9	1.6	2.3	1.8	2.6	1.9	2.8	2.0	2.9	2.0	3.1	2.0	3.3	1.9
	18	1.9	1.6	2.3	1.8	2.6	1.9	2.8	2.0	2.9	2.0	3.1	2.0	3.3	1.9
	20	1.9	1.6	2.3	1.8	2.6	1.9	2.8	2.0	2.9	2.0	3.1	2.0	3.3	1.9
	21	1.9	1.6	2.3	1.8	2.6	1.9	2.8	2.0	2.9	2.0	3.1	2.0	3.3	1.9
	23	1.9	1.6	2.3	1.8	2.6	1.9	2.8	2.0	2.9	2.0	3.1	2.0	3.3	1.9
	25	1.9	1.6	2.3	1.8	2.6	1.9	2.8	2.0	2.9	2.0	3.1	2.0	3.3	1.9
	27	1.9	1.6	2.3	1.8	2.6	1.9	2.8	2.0	2.9	2.0	3.1	2.0	3.3	1.9
	29	1.9	1.6	2.3	1.8	2.6	1.9	2.8	2.0	2.9	2.0	3.1	2.0	3.3	1.9
	31	1.9	1.6	2.3	1.8	2.6	1.9	2.8	2.0	2.9	2.0	3.1	2.0	3.3	1.9
	33	1.9	1.6	2.3	1.8	2.6	1.9	2.8	2.0	2.9	2.0	3.1	2.0	3.3	1.9
	35	1.9	1.6	2.3	1.8	2.6	1.9	2.8	2.0	2.9	2.0	3.1	2.0	3.3	1.9
	37	1.9	1.6	2.3	1.8	2.6	1.9	2.8	2.0	2.9	2.0	3.1	2.0	3.3	1.9
39	1.9	1.6	2.3	1.8	2.6	1.9	2.8	2.0	2.9	2.0	3.0	1.9	3.2	1.8	
42	1.9	1.6	2.3	1.8	2.6	1.9	2.8	2.0	2.9	2.0	2.9	1.9	3.1	1.8	
44	1.9	1.6	2.3	1.8	2.5	1.8	2.7	1.9	2.8	1.9	2.8	1.8	3.0	1.7	
46	1.9	1.6	2.3	1.8	2.5	1.8	2.6	1.8	2.7	1.9	2.7	1.7	2.9	1.6	
48	1.9	1.6	2.2	1.8	2.4	1.8	2.5	1.8	2.6	1.8	2.7	1.7	2.8	1.6	

2 Capacity Table

Slim Duct

Cooling

TC : Total Capacity(kW), SHC : Sensible Heat Capacity(kW)

Capacity Index	Outdoor Air Temp. (°C, DB)	Indoor temperature													
		20(°C, DB)		23(°C, DB)		26(°C, DB)		27(°C, DB)		28(°C, DB)		30(°C, DB)		32(°C, DB)	
		14(°C, WB)		16(°C, WB)		18(°C, WB)		19(°C, WB)		20(°C, WB)		22(°C, WB)		24(°C, WB)	
	TC	SHC	TC	SHC	TC	SHC	TC	SHC	TC	SHC	TC	SHC	TC	SHC	
036	10	2.5	2.0	2.9	2.3	3.4	2.5	3.6	2.6	3.7	2.6	4.0	2.6	4.3	2.5
	12	2.5	2.0	2.9	2.3	3.4	2.5	3.6	2.6	3.7	2.6	4.0	2.6	4.3	2.5
	14	2.5	2.0	2.9	2.3	3.4	2.5	3.6	2.6	3.7	2.6	4.0	2.6	4.3	2.5
	16	2.5	2.0	2.9	2.3	3.4	2.5	3.6	2.6	3.7	2.6	4.0	2.6	4.3	2.5
	18	2.5	2.0	2.9	2.3	3.4	2.5	3.6	2.6	3.7	2.6	4.0	2.6	4.2	2.4
	20	2.5	2.0	2.9	2.3	3.4	2.5	3.6	2.6	3.7	2.6	4.0	2.6	4.2	2.4
	21	2.5	2.0	2.9	2.3	3.4	2.5	3.6	2.6	3.7	2.6	4.0	2.6	4.2	2.4
	23	2.5	2.0	2.9	2.3	3.4	2.5	3.6	2.6	3.7	2.6	4.0	2.6	4.2	2.4
	25	2.5	2.0	2.9	2.3	3.4	2.5	3.6	2.6	3.7	2.6	4.0	2.6	4.2	2.4
	27	2.5	2.0	2.9	2.3	3.4	2.5	3.6	2.6	3.7	2.6	4.0	2.6	4.2	2.4
	29	2.5	2.0	2.9	2.3	3.4	2.5	3.6	2.6	3.7	2.6	4.0	2.6	4.2	2.4
	31	2.5	2.0	2.9	2.3	3.4	2.5	3.6	2.6	3.7	2.6	4.0	2.6	4.2	2.4
	33	2.5	2.0	2.9	2.3	3.4	2.5	3.6	2.6	3.7	2.6	4.0	2.6	4.2	2.4
	35	2.5	2.0	2.9	2.3	3.4	2.5	3.6	2.6	3.7	2.6	4.0	2.6	4.2	2.4
	37	2.5	2.0	2.9	2.3	3.4	2.5	3.6	2.6	3.7	2.6	3.9	2.5	4.2	2.4
	39	2.5	2.0	2.9	2.3	3.4	2.5	3.6	2.6	3.7	2.6	3.9	2.5	4.1	2.3
42	2.5	2.0	2.9	2.3	3.4	2.5	3.6	2.6	3.7	2.6	3.8	2.5	4.0	2.2	
44	2.5	2.0	2.9	2.3	3.3	2.4	3.4	2.5	3.6	2.5	3.7	2.4	3.9	2.2	
46	2.5	2.0	2.9	2.3	3.2	2.4	3.3	2.4	3.4	2.4	3.6	2.3	3.8	2.1	
48	2.5	2.0	2.8	2.2	3.2	2.3	3.2	2.3	3.4	2.4	3.5	2.2	3.6	2.0	
045	10	3.1	2.7	3.7	3.1	4.2	3.2	4.5	3.3	4.7	3.3	5.0	3.3	5.4	3.4
	12	3.1	2.7	3.7	3.1	4.2	3.2	4.5	3.3	4.7	3.3	5.0	3.3	5.4	3.4
	14	3.1	2.7	3.7	3.1	4.2	3.2	4.5	3.3	4.7	3.3	5.0	3.3	5.4	3.4
	16	3.1	2.7	3.7	3.1	4.2	3.2	4.5	3.3	4.7	3.3	5.0	3.3	5.3	3.1
	18	3.1	2.7	3.7	3.1	4.2	3.2	4.5	3.3	4.7	3.3	5.0	3.3	5.3	3.1
	20	3.1	2.7	3.7	3.1	4.2	3.2	4.5	3.3	4.7	3.3	5.0	3.3	5.3	3.1
	21	3.1	2.7	3.7	3.1	4.2	3.2	4.5	3.3	4.7	3.3	5.0	3.3	5.3	3.1
	23	3.1	2.7	3.7	3.1	4.2	3.2	4.5	3.3	4.7	3.3	5.0	3.3	5.3	3.1
	25	3.1	2.7	3.7	3.1	4.2	3.2	4.5	3.3	4.7	3.3	5.0	3.3	5.3	3.1
	27	3.1	2.7	3.7	3.1	4.2	3.2	4.5	3.3	4.7	3.3	5.0	3.3	5.3	3.1
	29	3.1	2.7	3.7	3.1	4.2	3.2	4.5	3.3	4.7	3.3	5.0	3.3	5.3	3.1
	31	3.1	2.7	3.7	3.1	4.2	3.2	4.5	3.3	4.7	3.3	5.0	3.3	5.3	3.1
	33	3.1	2.7	3.7	3.1	4.2	3.2	4.5	3.3	4.7	3.3	5.0	3.3	5.3	3.1
	35	3.1	2.7	3.7	3.1	4.2	3.2	4.5	3.3	4.7	3.3	5.0	3.3	5.3	3.1
	37	3.1	2.7	3.7	3.1	4.2	3.2	4.5	3.3	4.6	3.2	4.9	3.2	5.2	3.1
	39	3.1	2.7	3.7	3.1	4.2	3.2	4.5	3.3	4.6	3.2	4.9	3.2	5.1	3.0
42	3.1	2.7	3.7	3.1	4.2	3.2	4.4	3.3	4.5	3.2	4.8	3.1	5.0	2.9	
44	3.1	2.7	3.7	3.1	4.1	3.1	4.3	3.2	4.4	3.1	4.6	3.0	4.8	2.8	
46	3.1	2.7	3.7	3.1	4.0	3.0	4.2	3.1	4.3	3.0	4.5	2.9	4.7	2.7	
48	3.1	2.6	3.6	3.0	3.9	3.0	4.0	3.0	4.2	2.9	4.3	2.8	4.5	2.6	
056	10	3.9	3.3	4.6	3.8	5.3	4.0	5.6	4.2	5.8	4.2	6.3	4.3	6.7	4.1
	12	3.9	3.3	4.6	3.8	5.3	4.0	5.6	4.2	5.8	4.2	6.3	4.3	6.7	4.1
	14	3.9	3.3	4.6	3.8	5.3	4.0	5.6	4.2	5.8	4.2	6.2	4.2	6.7	4.1
	16	3.9	3.3	4.6	3.8	5.3	4.0	5.6	4.2	5.8	4.2	6.2	4.2	6.6	4.0
	18	3.9	3.3	4.6	3.8	5.3	4.0	5.6	4.2	5.8	4.2	6.2	4.2	6.6	4.0
	20	3.9	3.3	4.6	3.8	5.3	4.0	5.6	4.2	5.8	4.2	6.2	4.2	6.6	4.0
	21	3.9	3.3	4.6	3.8	5.3	4.0	5.6	4.2	5.8	4.2	6.2	4.2	6.6	4.0
	23	3.9	3.3	4.6	3.8	5.3	4.0	5.6	4.2	5.8	4.2	6.2	4.2	6.6	4.0
	25	3.9	3.3	4.6	3.8	5.3	4.0	5.6	4.2	5.8	4.2	6.2	4.2	6.6	4.0
	27	3.9	3.3	4.6	3.8	5.3	4.0	5.6	4.2	5.8	4.2	6.2	4.2	6.6	4.0
	29	3.9	3.3	4.6	3.8	5.3	4.0	5.6	4.2	5.8	4.2	6.2	4.2	6.6	4.0
	31	3.9	3.3	4.6	3.8	5.3	4.0	5.6	4.2	5.8	4.2	6.2	4.2	6.6	4.0
	33	3.9	3.3	4.6	3.8	5.3	4.0	5.6	4.2	5.8	4.2	6.2	4.2	6.6	4.0
	35	3.9	3.3	4.6	3.8	5.3	4.0	5.6	4.2	5.8	4.2	6.2	4.2	6.6	4.0
	37	3.9	3.3	4.6	3.8	5.3	4.0	5.6	4.2	5.8	4.2	6.1	4.1	6.5	3.9
	39	3.9	3.3	4.6	3.8	5.3	4.0	5.6	4.2	5.8	4.2	6.1	4.1	6.4	3.8
42	3.9	3.3	4.6	3.8	5.3	4.0	5.5	4.1	5.7	4.2	6.0	4.0	6.2	3.7	
44	3.9	3.3	4.6	3.8	5.1	3.9	5.3	4.0	5.6	4.0	5.8	3.9	6.0	3.6	
46	3.9	3.3	4.6	3.7	5.0	3.8	5.2	3.9	5.4	3.9	5.6	3.7	5.9	3.5	
48	3.9	3.2	4.5	3.7	5.0	3.7	5.0	3.8	5.3	3.8	5.4	3.6	5.7	3.3	

2 Capacity Table

Slim Duct

Cooling

TC : Total Capacity(kW), SHC : Sensible Heat Capacity(kW)

Capacity Index	Outdoor Air Temp. (°C, DB)	Indoor temperature													
		20(°C, DB)		23(°C, DB)		26(°C, DB)		27(°C, DB)		28(°C, DB)		30(°C, DB)		32(°C, DB)	
		14(°C, WB)		16(°C, WB)		18(°C, WB)		19(°C, WB)		20(°C, WB)		22(°C, WB)		24(°C, WB)	
	TC	SHC	TC	SHC	TC	SHC	TC	SHC	TC	SHC	TC	SHC	TC	SHC	
071	10	4.9	4.3	5.8	5.0	6.7	5.2	7.1	5.4	7.4	5.6	8.0	5.7	8.5	5.4
	12	4.9	4.3	5.8	5.0	6.7	5.2	7.1	5.4	7.4	5.6	7.9	5.6	8.5	5.4
	14	4.9	4.3	5.8	5.0	6.7	5.2	7.1	5.4	7.4	5.6	7.9	5.6	8.5	5.4
	16	4.9	4.3	5.8	5.0	6.7	5.2	7.1	5.4	7.4	5.6	7.9	5.6	8.4	5.3
	18	4.9	4.3	5.8	5.0	6.7	5.2	7.1	5.4	7.4	5.6	7.9	5.6	8.4	5.3
	20	4.9	4.3	5.8	5.0	6.7	5.2	7.1	5.4	7.4	5.6	7.9	5.6	8.4	5.3
	21	4.9	4.3	5.8	5.0	6.7	5.2	7.1	5.4	7.4	5.6	7.9	5.6	8.4	5.3
	23	4.9	4.3	5.8	5.0	6.7	5.2	7.1	5.4	7.4	5.6	7.9	5.6	8.4	5.3
	25	4.9	4.3	5.8	5.0	6.7	5.2	7.1	5.4	7.4	5.6	7.9	5.6	8.4	5.3
	27	4.9	4.3	5.8	5.0	6.7	5.2	7.1	5.4	7.4	5.6	7.9	5.6	8.4	5.3
	29	4.9	4.3	5.8	5.0	6.7	5.2	7.1	5.4	7.4	5.6	7.9	5.6	8.4	5.3
	31	4.9	4.3	5.8	5.0	6.7	5.2	7.1	5.4	7.4	5.6	7.9	5.6	8.4	5.3
	33	4.9	4.3	5.8	5.0	6.7	5.2	7.1	5.4	7.4	5.6	7.9	5.6	8.4	5.3
	35	4.9	4.3	5.8	5.0	6.7	5.2	7.1	5.4	7.4	5.6	7.9	5.6	8.4	5.3
	37	4.9	4.3	5.8	5.0	6.7	5.2	7.1	5.4	7.3	5.5	7.8	5.5	8.2	5.2
	39	4.9	4.3	5.8	5.0	6.7	5.2	7.1	5.4	7.3	5.5	7.7	5.4	8.1	5.1
42	4.9	4.3	5.8	5.0	6.7	5.2	7.0	5.3	7.2	5.4	7.6	5.3	7.9	5.0	
44	4.9	4.3	5.8	5.0	6.5	5.0	6.8	5.2	7.0	5.3	7.3	5.1	7.6	4.8	
46	4.9	4.3	5.7	5.0	6.4	4.9	6.6	5.0	6.8	5.1	7.0	4.9	7.4	4.7	
48	4.8	4.2	5.7	4.9	6.3	4.9	6.4	4.9	6.7	5.0	6.8	4.8	7.2	4.5	
090	10	6.2	5.7	7.3	6.5	8.4	6.9	9.0	7.1	9.4	7.3	10.1	7.3	10.8	7.3
	12	6.2	5.7	7.3	6.5	8.4	6.9	9.0	7.1	9.4	7.3	10.1	7.3	10.8	7.3
	14	6.2	5.7	7.3	6.5	8.4	6.9	9.0	7.1	9.3	7.2	10.0	7.2	10.7	7.1
	16	6.2	5.7	7.3	6.5	8.4	6.9	9.0	7.1	9.3	7.2	10.0	7.2	10.7	7.1
	18	6.2	5.7	7.3	6.5	8.4	6.9	9.0	7.1	9.3	7.2	10.0	7.2	10.6	7.0
	20	6.2	5.7	7.3	6.5	8.4	6.9	9.0	7.1	9.3	7.2	10.0	7.2	10.6	7.0
	21	6.2	5.7	7.3	6.5	8.4	6.9	9.0	7.1	9.3	7.2	10.0	7.2	10.6	7.0
	23	6.2	5.7	7.3	6.5	8.4	6.9	9.0	7.1	9.3	7.2	10.0	7.2	10.6	7.0
	25	6.2	5.7	7.3	6.5	8.4	6.9	9.0	7.1	9.3	7.2	10.0	7.2	10.6	7.0
	27	6.2	5.7	7.3	6.5	8.4	6.9	9.0	7.1	9.3	7.2	10.0	7.2	10.6	7.0
	29	6.2	5.7	7.3	6.5	8.4	6.9	9.0	7.1	9.3	7.2	10.0	7.2	10.6	7.0
	31	6.2	5.7	7.3	6.5	8.4	6.9	9.0	7.1	9.3	7.2	10.0	7.2	10.6	7.0
	33	6.2	5.7	7.3	6.5	8.4	6.9	9.0	7.1	9.3	7.2	10.0	7.2	10.6	7.0
	35	6.2	5.7	7.3	6.5	8.4	6.9	9.0	7.1	9.3	7.2	10.0	7.2	10.6	7.0
	37	6.2	5.7	7.3	6.5	8.4	6.9	9.0	7.1	9.3	7.2	9.9	7.1	10.4	6.9
	39	6.2	5.7	7.3	6.5	8.4	6.9	9.0	7.1	9.2	7.1	9.7	7.0	10.2	6.8
42	6.2	5.7	7.3	6.5	8.3	6.8	8.9	7.0	9.1	7.0	9.5	6.9	9.9	6.6	
44	6.2	5.7	7.3	6.5	8.1	6.7	8.6	6.8	8.8	6.8	9.2	6.6	9.6	6.4	
46	6.2	5.7	7.2	6.4	8.0	6.6	8.3	6.6	8.6	6.6	8.9	6.4	9.3	6.2	
48	6.1	5.6	7.1	6.3	7.8	6.4	8.1	6.4	8.4	6.5	8.6	6.2	9.0	6.0	
112	10	7.7	6.8	9.1	7.7	10.5	8.2	11.2	8.6	11.6	8.8	12.5	8.9	13.4	8.6
	12	7.7	6.8	9.1	7.7	10.5	8.2	11.2	8.6	11.6	8.8	12.5	8.9	13.4	8.6
	14	7.7	6.8	9.1	7.7	10.5	8.2	11.2	8.6	11.6	8.8	12.5	8.9	13.4	8.6
	16	7.7	6.8	9.1	7.7	10.5	8.2	11.2	8.6	11.6	8.8	12.5	8.9	13.3	8.5
	18	7.7	6.8	9.1	7.7	10.5	8.2	11.2	8.6	11.6	8.8	12.5	8.9	13.3	8.5
	20	7.7	6.8	9.1	7.7	10.5	8.2	11.2	8.6	11.6	8.8	12.4	8.8	13.2	8.5
	21	7.7	6.8	9.1	7.7	10.5	8.2	11.2	8.6	11.6	8.8	12.4	8.8	13.2	8.5
	23	7.7	6.8	9.1	7.7	10.5	8.2	11.2	8.6	11.6	8.8	12.4	8.8	13.2	8.5
	25	7.7	6.8	9.1	7.7	10.5	8.2	11.2	8.6	11.6	8.8	12.4	8.8	13.2	8.5
	27	7.7	6.8	9.1	7.7	10.5	8.2	11.2	8.6	11.6	8.8	12.4	8.8	13.2	8.5
	29	7.7	6.8	9.1	7.7	10.5	8.2	11.2	8.6	11.6	8.8	12.4	8.8	13.2	8.5
	31	7.7	6.8	9.1	7.7	10.5	8.2	11.2	8.6	11.6	8.8	12.4	8.8	13.2	8.5
	33	7.7	6.8	9.1	7.7	10.5	8.2	11.2	8.6	11.6	8.8	12.4	8.8	13.2	8.5
	35	7.7	6.8	9.1	7.7	10.5	8.2	11.2	8.6	11.6	8.8	12.4	8.7	13.2	8.5
	37	7.7	6.8	9.1	7.7	10.5	8.2	11.2	8.6	11.6	8.8	12.4	8.9	13.2	8.5
	39	7.7	6.8	9.1	7.7	10.5	8.2	11.2	8.6	11.6	8.8	12.3	8.8	13.0	8.4
42	7.7	6.8	9.1	7.7	10.4	8.1	11.1	8.5	11.5	8.7	12.1	8.6	12.7	8.2	
44	7.7	6.8	9.1	7.7	10.1	7.9	10.7	8.2	11.1	8.4	11.6	8.3	12.2	7.9	
46	7.7	6.8	9.0	7.6	10.0	7.8	10.4	8.0	10.8	8.2	11.2	8.0	11.9	7.7	
48	7.6	6.7	8.9	7.5	9.8	7.7	10.1	7.7	10.6	8.0	10.9	7.8	11.5	7.4	

2 Capacity Table

Slim Duct

Cooling

TC : Total Capacity(kW), SHC : Sensible Heat Capacity(kW)

Capacity Index	Outdoor Air Temp. (°C, DB)	Indoor temperature													
		20(°C, DB)		23(°C, DB)		26(°C, DB)		27(°C, DB)		28(°C, DB)		30(°C, DB)		32(°C, DB)	
		14(°C, WB)		16(°C, WB)		18(°C, WB)		19(°C, WB)		20(°C, WB)		22(°C, WB)		24(°C, WB)	
		TC	SHC	TC	SHC	TC	SHC	TC	SHC	TC	SHC	TC	SHC	TC	SHC
128	10	8.8	7.8	10.4	8.9	12.0	9.5	12.8	9.9	13.3	9.9	14.3	10.0	15.4	9.9
	12	8.8	7.8	10.4	8.9	12.0	9.5	12.8	9.9	13.3	9.9	14.3	10.0	15.3	9.8
	14	8.8	7.8	10.4	8.9	12.0	9.5	12.8	9.9	13.3	9.9	14.3	10.0	15.3	9.8
	16	8.8	7.8	10.4	8.9	12.0	9.5	12.8	9.9	13.3	9.9	14.2	9.9	15.2	9.8
	18	8.8	7.8	10.4	8.9	12.0	9.5	12.8	9.9	13.3	9.9	14.2	9.9	15.1	9.7
	20	8.8	7.8	10.4	8.9	12.0	9.5	12.8	9.9	13.3	9.9	14.2	9.9	15.1	9.7
	21	8.8	7.8	10.4	8.9	12.0	9.5	12.8	9.9	13.3	9.9	14.2	9.9	15.1	9.7
	23	8.8	7.8	10.4	8.9	12.0	9.5	12.8	9.9	13.3	9.9	14.2	9.9	15.1	9.7
	25	8.8	7.8	10.4	8.9	12.0	9.5	12.8	9.9	13.3	9.9	14.2	9.9	15.1	9.7
	27	8.8	7.8	10.4	8.9	12.0	9.5	12.8	9.9	13.3	9.9	14.2	9.9	15.1	9.7
	29	8.8	7.8	10.4	8.9	12.0	9.5	12.8	9.9	13.3	9.9	14.2	9.9	15.1	9.7
	31	8.8	7.8	10.4	8.9	12.0	9.5	12.8	9.9	13.3	9.9	14.2	9.9	15.1	9.7
	33	8.8	7.8	10.4	8.9	12.0	9.5	12.8	9.9	13.3	9.9	14.2	9.9	15.1	9.7
	35	8.8	7.8	10.4	8.9	12.0	9.5	12.8	9.9	13.3	9.9	14.2	9.9	15.1	9.7
	37	8.8	7.8	10.4	8.9	12.0	9.5	12.8	9.9	13.2	9.9	14.0	9.8	14.9	9.6
	39	8.8	7.8	10.4	8.9	12.0	9.5	12.8	9.9	13.1	9.8	13.8	9.6	14.5	9.4
42	8.8	7.8	10.4	8.9	11.9	9.4	12.6	9.8	12.9	9.7	13.6	9.4	14.1	9.2	
44	8.8	7.8	10.4	8.9	11.6	9.2	12.2	9.5	12.6	9.4	13.0	9.1	13.6	8.8	
46	8.8	7.8	10.3	8.8	11.4	9.0	11.8	9.2	12.2	9.1	12.6	8.8	13.3	8.6	
48	8.7	7.7	10.2	8.7	11.2	8.9	11.5	8.9	12.0	8.9	12.2	8.5	12.8	8.3	
140	10	9.7	8.6	11.4	9.7	13.1	10.5	14.0	10.8	14.6	10.9	15.7	11.0	16.8	10.9
	12	9.7	8.6	11.4	9.7	13.1	10.5	14.0	10.8	14.5	10.8	15.6	10.9	16.7	10.8
	14	9.7	8.6	11.4	9.7	13.1	10.5	14.0	10.8	14.5	10.8	15.6	10.9	16.7	10.8
	16	9.7	8.6	11.4	9.7	13.1	10.5	14.0	10.8	14.5	10.8	15.6	10.9	16.6	10.7
	18	9.7	8.6	11.4	9.7	13.1	10.5	14.0	10.8	14.5	10.8	15.5	10.8	16.6	10.7
	20	9.7	8.6	11.4	9.7	13.1	10.5	14.0	10.8	14.5	10.8	15.5	10.8	16.5	10.6
	21	9.7	8.6	11.4	9.7	13.1	10.5	14.0	10.8	14.5	10.8	15.5	10.8	16.5	10.6
	23	9.7	8.6	11.4	9.7	13.1	10.5	14.0	10.8	14.5	10.8	15.5	10.8	16.5	10.6
	25	9.7	8.6	11.4	9.7	13.1	10.5	14.0	10.8	14.5	10.8	15.5	10.8	16.5	10.6
	27	9.7	8.6	11.4	9.7	13.1	10.5	14.0	10.8	14.5	10.8	15.5	10.8	16.5	10.6
	29	9.7	8.6	11.4	9.7	13.1	10.5	14.0	10.8	14.5	10.8	15.5	10.8	16.5	10.6
	31	9.7	8.6	11.4	9.7	13.1	10.5	14.0	10.8	14.5	10.8	15.5	10.8	16.5	10.6
	33	9.7	8.6	11.4	9.7	13.1	10.5	14.0	10.8	14.5	10.8	15.5	10.8	16.5	10.6
	35	9.7	8.6	11.4	9.7	13.1	10.5	14.0	10.8	14.5	10.8	15.5	10.8	16.5	10.6
	37	9.7	8.6	11.4	9.7	13.1	10.5	14.0	10.8	14.5	10.8	15.4	10.7	16.3	10.5
	39	9.7	8.6	11.4	9.7	13.1	10.5	14.0	10.8	14.4	10.7	15.1	10.5	15.9	10.3
42	9.7	8.6	11.4	9.7	13.0	10.4	13.8	10.7	14.2	10.6	14.8	10.3	15.5	10.0	
44	9.7	8.6	11.4	9.7	12.7	10.1	13.4	10.3	13.8	10.3	14.2	9.9	15.0	9.7	
46	9.7	8.6	11.3	9.6	12.4	10.0	12.9	10.0	13.4	10.0	13.8	9.6	14.6	9.4	
48	9.6	8.5	11.1	9.5	12.2	9.8	12.6	9.7	13.1	9.8	13.4	9.3	14.1	9.1	

2 Capacity Table

Slim Duct

Heating

TC : Total Capacity(kW)

Capacity Index	Outdoor Air Temp. (°C)		Indoor temperature (°C,DB)				
			16(°C,DB)	18(°C,DB)	20(°C,DB)	22(°C,DB)	24(°C,DB)
	DB	WB	TC	TC	TC	TC	TC
017	-19.8	-20.0	1.1	1.1	1.1	1.1	1.1
	-18.8	-19.0	1.1	1.1	1.1	1.1	1.1
	-16.7	-17.0	1.2	1.2	1.2	1.2	1.2
	-14.7	-15.0	1.3	1.2	1.2	1.2	1.2
	-12.6	-13.0	1.4	1.4	1.4	1.4	1.3
	-10.5	-11.0	1.5	1.5	1.4	1.4	1.4
	-9.5	-10.0	1.6	1.5	1.5	1.4	1.4
	-8.5	-9.1	1.7	1.6	1.6	1.5	1.5
	-7.0	-7.6	1.8	1.7	1.7	1.5	1.5
	-5.0	-5.6	1.8	1.8	1.8	1.7	1.7
	-3.0	-3.7	1.9	1.9	1.8	1.8	1.7
	0.0	-0.7	2.0	1.9	1.9	1.8	1.7
	3.0	2.2	2.0	2.0	1.9	1.8	1.7
	5.0	4.1	2.1	2.0	1.9	1.8	1.7
	7.0	6.0	2.1	2.0	1.9	1.8	1.7
9.0	7.9	2.3	2.0	1.9	1.8	1.7	
11.0	9.8	2.3	2.0	1.9	1.8	1.7	
13.0	11.8	2.3	2.0	1.9	1.8	1.7	
15.0	13.7	2.3	2.0	1.9	1.8	1.7	
022	-19.8	-20.0	1.5	1.5	1.5	1.5	1.5
	-18.8	-19.0	1.5	1.5	1.5	1.5	1.5
	-16.7	-17.0	1.6	1.6	1.6	1.6	1.6
	-14.7	-15.0	1.7	1.6	1.6	1.6	1.6
	-12.6	-13.0	1.8	1.8	1.8	1.8	1.7
	-10.5	-11.0	2.0	2.0	1.9	1.9	1.9
	-9.5	-10.0	2.1	2.0	2.0	1.9	1.9
	-8.5	-9.1	2.2	2.1	2.1	2.0	2.0
	-7.0	-7.6	2.3	2.2	2.2	2.0	2.0
	-5.0	-5.6	2.4	2.3	2.3	2.2	2.2
	-3.0	-3.7	2.5	2.5	2.4	2.3	2.2
	0.0	-0.7	2.6	2.5	2.5	2.3	2.2
	3.0	2.2	2.7	2.6	2.5	2.3	2.2
	5.0	4.1	2.8	2.7	2.5	2.3	2.2
	7.0	6.0	2.8	2.7	2.5	2.3	2.2
9.0	7.9	3.0	2.7	2.5	2.3	2.2	
11.0	9.8	3.0	2.7	2.5	2.3	2.2	
13.0	11.8	3.0	2.7	2.5	2.3	2.2	
15.0	13.7	3.0	2.7	2.5	2.3	2.2	
028	-19.8	-20.0	1.9	1.9	1.9	1.9	1.9
	-18.8	-19.0	1.9	1.9	1.9	1.9	1.9
	-16.7	-17.0	2.0	2.0	2.0	2.0	1.9
	-14.7	-15.0	2.1	2.1	2.0	2.0	1.9
	-12.6	-13.0	2.2	2.2	2.2	2.1	2.1
	-10.5	-11.0	2.3	2.3	2.3	2.3	2.2
	-9.5	-10.0	2.3	2.3	2.3	2.3	2.2
	-8.5	-9.1	2.4	2.4	2.4	2.4	2.3
	-7.0	-7.6	2.5	2.4	2.4	2.4	2.3
	-5.0	-5.6	2.6	2.6	2.5	2.5	2.4
	-3.0	-3.7	2.8	2.7	2.7	2.6	2.5
	0.0	-0.7	2.9	2.8	2.8	2.7	2.6
	3.0	2.2	3.0	3.0	2.9	2.8	2.7
	5.0	4.1	3.2	3.1	3.1	2.9	2.7
	7.0	6.0	3.3	3.2	3.2	3.0	2.7
9.0	7.9	3.4	3.3	3.2	3.0	2.7	
11.0	9.8	3.5	3.3	3.2	3.0	2.7	
13.0	11.8	3.6	3.4	3.2	3.0	2.7	
15.0	13.7	3.7	3.4	3.2	3.0	2.7	

2 Capacity Table

Slim Duct

Heating

TC : Total Capacity(kW)

Capacity Index	Outdoor Air Temp. (°C)		Indoor temperature (°C,DB)				
			16(°C,DB)	18(°C,DB)	20(°C,DB)	22(°C,DB)	24(°C,DB)
	DB	WB	TC	TC	TC	TC	TC
036	-19.8	-20.0	2.4	2.4	2.3	2.3	2.3
	-18.8	-19.0	2.5	2.4	2.3	2.3	2.3
	-16.7	-17.0	2.6	2.5	2.4	2.4	2.3
	-14.7	-15.0	2.7	2.6	2.5	2.5	2.4
	-12.6	-13.0	2.8	2.7	2.7	2.6	2.6
	-10.5	-11.0	2.9	2.9	2.9	2.8	2.8
	-9.5	-10.0	2.9	2.9	2.9	2.8	2.8
	-8.5	-9.1	3.0	3.0	3.0	2.9	2.9
	-7.0	-7.6	3.1	3.1	3.0	3.0	2.9
	-5.0	-5.6	3.3	3.2	3.2	3.1	3.0
	-3.0	-3.7	3.4	3.4	3.3	3.2	3.1
	0.0	-0.7	3.6	3.6	3.5	3.4	3.2
	3.0	2.2	3.8	3.7	3.7	3.5	3.4
	5.0	4.1	3.9	3.9	3.8	3.6	3.4
	7.0	6.0	4.1	4.1	4.0	3.7	3.4
9.0	7.9	4.2	4.1	4.0	3.7	3.4	
11.0	9.8	4.4	4.2	4.0	3.7	3.4	
13.0	11.8	4.5	4.2	4.0	3.7	3.4	
15.0	13.7	4.6	4.3	4.0	3.7	3.4	
045	-19.8	-20.0	3.1	3.1	2.9	2.9	2.9
	-18.8	-19.0	3.1	3.1	3.0	2.9	2.9
	-16.7	-17.0	3.2	3.2	3.1	3.0	3.0
	-14.7	-15.0	3.3	3.3	3.2	3.1	3.0
	-12.6	-13.0	3.5	3.4	3.4	3.3	3.2
	-10.5	-11.0	3.7	3.6	3.6	3.5	3.4
	-9.5	-10.0	3.7	3.6	3.6	3.5	3.5
	-8.5	-9.1	3.8	3.7	3.7	3.6	3.6
	-7.0	-7.6	3.9	3.8	3.8	3.7	3.6
	-5.0	-5.6	4.1	4.0	4.0	3.9	3.7
	-3.0	-3.7	4.3	4.2	4.2	4.0	3.9
	0.0	-0.7	4.5	4.4	4.4	4.2	4.0
	3.0	2.2	4.7	4.7	4.6	4.4	4.2
	5.0	4.1	4.9	4.9	4.8	4.5	4.2
	7.0	6.0	5.1	5.1	5.0	4.6	4.2
9.0	7.9	5.3	5.2	5.0	4.6	4.2	
11.0	9.8	5.5	5.2	5.0	4.6	4.2	
13.0	11.8	5.6	5.3	5.0	4.6	4.2	
15.0	13.7	5.8	5.4	5.0	4.6	4.2	
056	-19.8	-20.0	3.9	3.8	3.8	3.7	3.7
	-18.8	-19.0	3.9	3.9	3.8	3.7	3.7
	-16.7	-17.0	4.0	4.0	3.9	3.8	3.8
	-14.7	-15.0	4.2	4.1	4.0	3.9	3.8
	-12.6	-13.0	4.4	4.3	4.2	4.1	4.0
	-10.5	-11.0	4.6	4.5	4.4	4.4	4.3
	-9.5	-10.0	4.7	4.6	4.6	4.5	4.4
	-8.5	-9.1	4.8	4.7	4.7	4.6	4.5
	-7.0	-7.6	4.9	4.8	4.8	4.7	4.5
	-5.0	-5.6	5.2	5.1	5.0	4.9	4.7
	-3.0	-3.7	5.4	5.3	5.3	5.1	4.9
	0.0	-0.7	5.7	5.6	5.5	5.3	5.0
	3.0	2.2	5.9	5.9	5.8	5.6	5.3
	5.0	4.1	6.2	6.1	6.0	5.7	5.3
	7.0	6.0	6.5	6.4	6.3	5.8	5.3
9.0	7.9	6.7	6.5	6.3	5.8	5.3	
11.0	9.8	6.9	6.6	6.3	5.8	5.3	
13.0	11.8	7.1	6.7	6.3	5.8	5.3	
15.0	13.7	7.3	6.8	6.3	5.8	5.3	

2 Capacity Table

Slim Duct

Heating

TC : Total Capacity(kW)

Capacity Index	Outdoor Air Temp. (°C)		Indoor temperature (°C,DB)				
			16(°C,DB)	18(°C,DB)	20(°C,DB)	22(°C,DB)	24(°C,DB)
	DB	WB	TC	TC	TC	TC	TC
071	-19.8	-20.0	4.9	4.9	4.8	4.7	4.7
	-18.8	-19.0	5.0	4.9	4.8	4.7	4.7
	-16.7	-17.0	5.1	5.0	4.9	4.8	4.8
	-14.7	-15.0	5.3	5.2	5.1	4.9	4.8
	-12.6	-13.0	5.5	5.4	5.3	5.2	5.1
	-10.5	-11.0	5.8	5.7	5.6	5.5	5.5
	-9.5	-10.0	6.0	5.9	5.8	5.7	5.6
	-8.5	-9.1	6.1	6.0	5.9	5.8	5.7
	-7.0	-7.6	6.2	6.1	6.0	5.9	5.8
	-5.0	-5.6	6.5	6.5	6.4	6.2	6.0
	-3.0	-3.7	6.9	6.8	6.7	6.4	6.2
	0.0	-0.7	7.2	7.1	7.0	6.7	6.4
	3.0	2.2	7.6	7.5	7.3	7.1	6.8
	5.0	4.1	7.9	7.8	7.7	7.2	6.8
	7.0	6.0	8.2	8.1	8.0	7.4	6.8
9.0	7.9	8.5	8.2	8.0	7.4	6.8	
11.0	9.8	8.7	8.4	8.0	7.4	6.8	
13.0	11.8	9.0	8.5	8.0	7.4	6.8	
15.0	13.7	9.2	8.6	8.0	7.4	6.8	
090	-19.8	-20.0	6.0	6.0	5.9	5.8	5.8
	-18.8	-19.0	6.1	6.1	6.0	5.9	5.8
	-16.7	-17.0	6.4	6.3	6.1	6.0	5.9
	-14.7	-15.0	6.7	6.5	6.3	6.2	6.1
	-12.6	-13.0	6.9	6.8	6.6	6.5	6.4
	-10.5	-11.0	7.2	7.1	7.0	6.9	6.9
	-9.5	-10.0	7.4	7.3	7.2	7.1	7.0
	-8.5	-9.1	7.6	7.5	7.4	7.2	7.1
	-7.0	-7.6	7.8	7.7	7.6	7.4	7.2
	-5.0	-5.6	8.2	8.1	8.0	7.7	7.5
	-3.0	-3.7	8.6	8.5	8.4	8.1	7.7
	0.0	-0.7	9.0	8.9	8.8	8.4	8.0
	3.0	2.2	9.4	9.3	9.2	8.8	8.4
	5.0	4.1	9.9	9.7	9.6	9.0	8.4
	7.0	6.0	10.3	10.1	10.0	9.2	8.4
9.0	7.9	10.6	10.3	10.0	9.2	8.4	
11.0	9.8	10.9	10.5	10.0	9.2	8.4	
13.0	11.8	11.2	10.6	10.0	9.2	8.4	
15.0	13.7	11.6	10.8	10.0	9.2	8.4	
112	-19.8	-20.0	7.4	7.4	7.3	7.3	7.3
	-18.8	-19.0	7.6	7.6	7.4	7.4	7.3
	-16.7	-17.0	8.1	7.8	7.6	7.5	7.4
	-14.7	-15.0	8.4	8.2	8.0	7.8	7.6
	-12.6	-13.0	8.7	8.5	8.3	8.1	8.0
	-10.5	-11.0	9.1	8.9	8.8	8.7	8.6
	-9.5	-10.0	9.3	9.1	9.0	8.9	8.8
	-8.5	-9.1	9.5	9.3	9.2	9.0	8.9
	-7.0	-7.6	9.7	9.6	9.4	9.2	9.0
	-5.0	-5.6	10.2	10.1	9.9	9.6	9.3
	-3.0	-3.7	10.7	10.6	10.5	10.1	9.7
	0.0	-0.7	11.3	11.1	11.1	10.5	10.0
	3.0	2.2	11.8	11.6	11.5	11.0	10.6
	5.0	4.1	12.3	12.2	12.0	11.3	10.6
	7.0	6.0	12.9	12.7	12.5	11.5	10.6
9.0	7.9	13.3	12.9	12.5	11.5	10.6	
11.0	9.8	13.7	13.1	12.5	11.5	10.6	
13.0	11.8	14.0	13.3	12.5	11.5	10.6	
15.0	13.7	14.4	13.5	12.5	11.5	10.6	

2 Capacity Table

Slim Duct

Heating

TC : Total Capacity(kW)

Capacity Index	Outdoor Air Temp. (°C)		Indoor temperature (°C,DB)				
			16(°C,DB)	18(°C,DB)	20(°C,DB)	22(°C,DB)	24(°C,DB)
	DB	WB	TC	TC	TC	TC	TC
128	-19.8	-20.0	8.1	8.1	8.0	8.0	8.0
	-18.8	-19.0	8.3	8.3	8.2	8.1	8.0
	-16.7	-17.0	8.8	8.6	8.4	8.3	8.1
	-14.7	-15.0	9.3	9.1	8.8	8.6	8.3
	-12.6	-13.0	9.6	9.4	9.2	9.0	8.8
	-10.5	-11.0	10.0	9.9	9.8	9.6	9.4
	-9.5	-10.0	10.2	10.1	10.0	9.8	9.7
	-8.5	-9.1	10.4	10.3	10.2	10.0	9.8
	-7.0	-7.6	10.7	10.6	10.4	10.2	10.0
	-5.0	-5.6	11.3	11.1	11.0	10.7	10.3
	-3.0	-3.7	11.9	11.7	11.5	11.1	10.7
	0.0	-0.7	12.4	12.3	12.1	11.6	11.0
	3.0	2.2	13.0	12.9	12.7	12.2	11.7
	5.0	4.1	13.6	13.4	13.2	12.4	11.7
	7.0	6.0	14.2	14.0	13.8	12.7	11.7
9.0	7.9	14.6	14.2	13.8	12.7	11.7	
140	11.0	9.8	15.1	14.4	13.8	12.7	11.7
	13.0	11.8	15.5	14.7	13.8	12.7	11.7
	15.0	13.7	15.9	14.9	13.8	12.7	11.7
	-19.8	-20.0	9.5	9.5	9.4	9.4	9.3
	-18.8	-19.0	9.7	9.7	9.5	9.5	9.3
	-16.7	-17.0	10.2	10.0	9.7	9.6	9.4
	-14.7	-15.0	10.8	10.5	10.2	9.9	9.6
	-12.6	-13.0	11.1	10.9	10.7	10.4	10.1
	-10.5	-11.0	11.6	11.5	11.3	11.1	10.9
	-9.5	-10.0	11.8	11.7	11.5	11.4	11.2
	-8.5	-9.1	12.1	11.9	11.8	11.6	11.3
	-7.0	-7.6	12.4	12.2	12.1	11.8	11.5
	-5.0	-5.6	13.1	12.9	12.7	12.3	12.0
	-3.0	-3.7	13.8	13.6	13.4	12.9	12.4
	0.0	-0.7	14.4	14.2	14.0	13.4	12.8
3.0	2.2	15.1	14.9	14.7	14.1	13.5	
5.0	4.1	15.8	15.6	15.3	14.4	13.5	
7.0	6.0	16.5	16.2	16.0	14.8	13.5	
9.0	7.9	17.0	16.5	16.0	14.8	13.5	
11.0	9.8	17.5	16.7	16.0	14.8	13.5	
13.0	11.8	18.0	17.0	16.0	14.8	13.5	
15.0	13.7	18.5	17.2	16.0	14.8	13.5	

3 Dimensional Drawing

Slim Duct

AM017/022/028/036FNLDEH/EU

[Unit : mm]

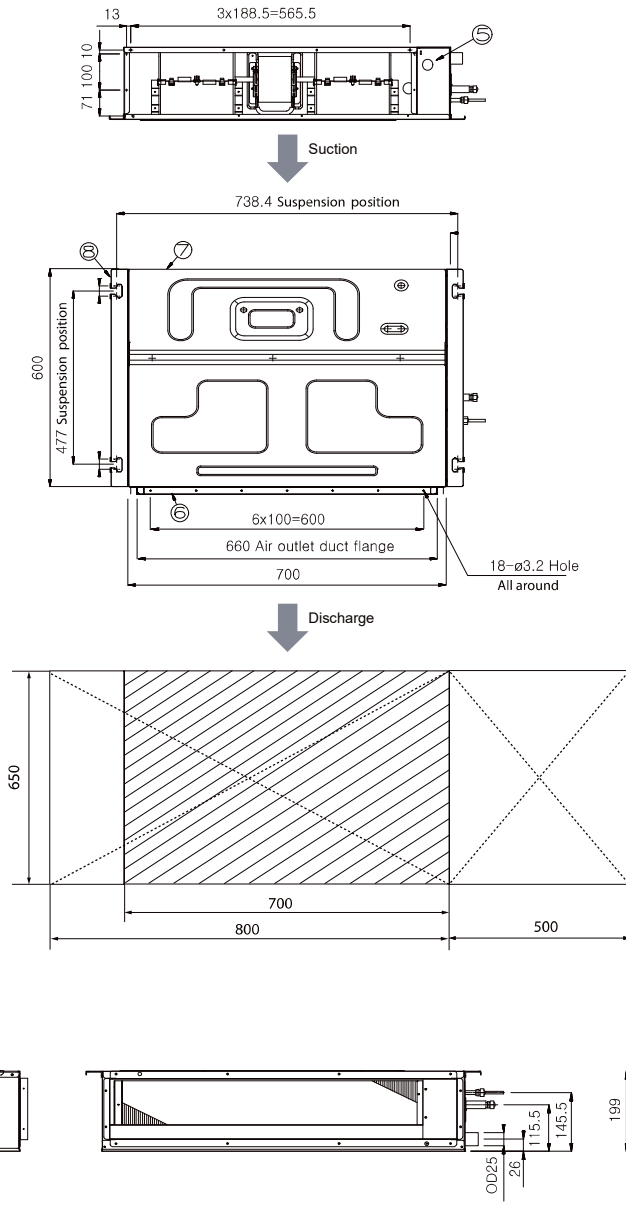

No.	Name	Description
1	Liquid pipe connection	ø6.35
2	Gas pipe connection	ø12.70
3	Drain pipe connection without drain pump	VP25 (OD ø32, ID ø25)
4	Drain pipe connection with drain pump	VP25 (OD ø32, ID ø25)
5	Power supply/Communication connection	-
6	Air discharge grille flange	-
7	Return air side	-
8	Hook	ø9.52 or M10

3 Dimensional Drawing

Slim Duct (Home)

AM017/022/028/036KNLDEH/EU

[Unit : mm]

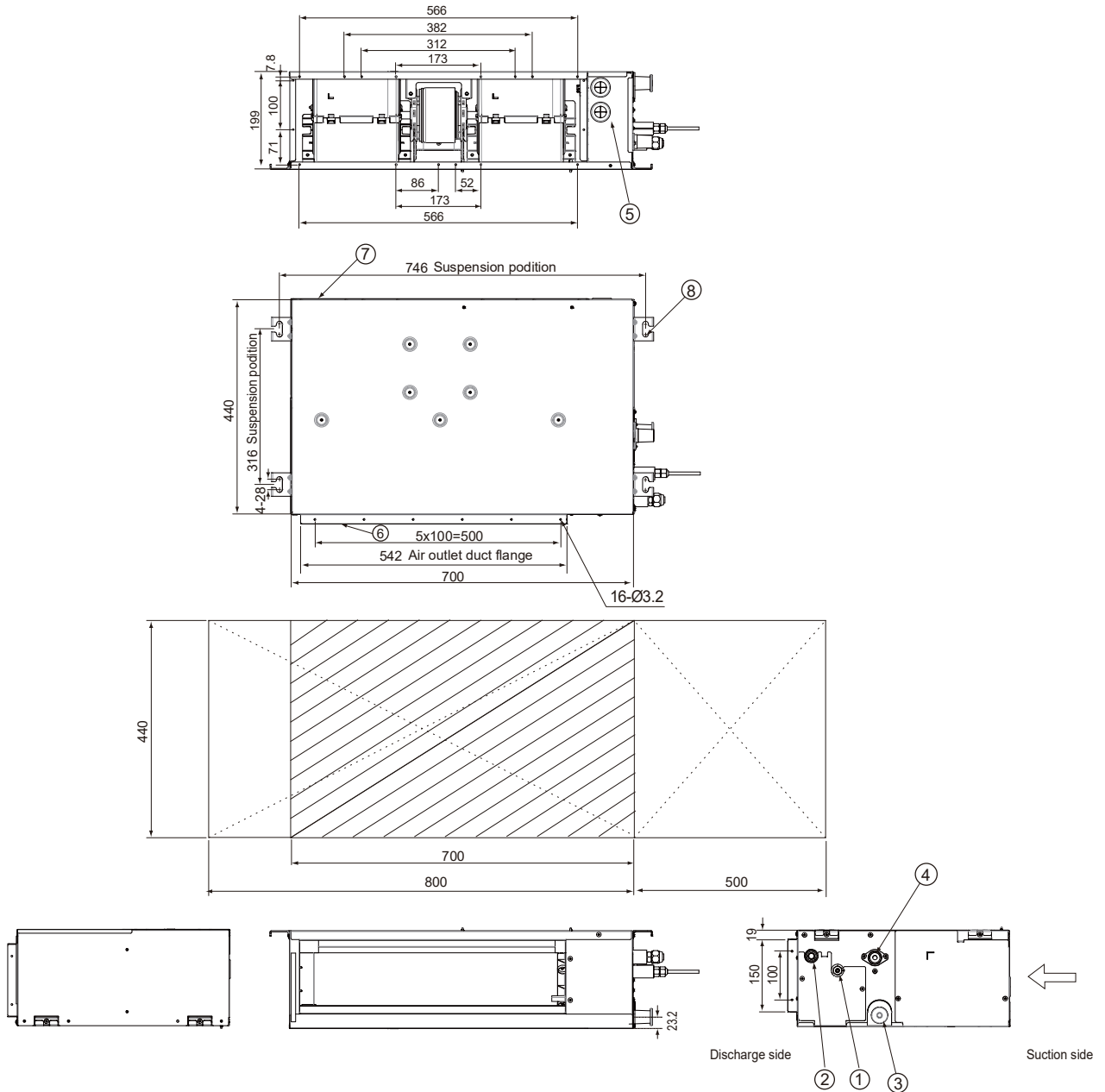

No.	Name	Description
1	Liquid pipe connection	Ø6.35
2	Gas pipe connection	Ø12.70
3	Drain pipe connection without drain pump	VP25 (OD Ø32, ID Ø25)
4	Drain pipe connection with drain pump	VP25 (OD Ø32, ID Ø25)
5	Power supply/Communication connection	-
6	Air discharge grille flange	-
7	Return air side	-
8	Hook	Ø9.52 or M10

3 Dimensional Drawing

Slim Duct

AM045/056*NLDEH/EU

[Unit : mm]

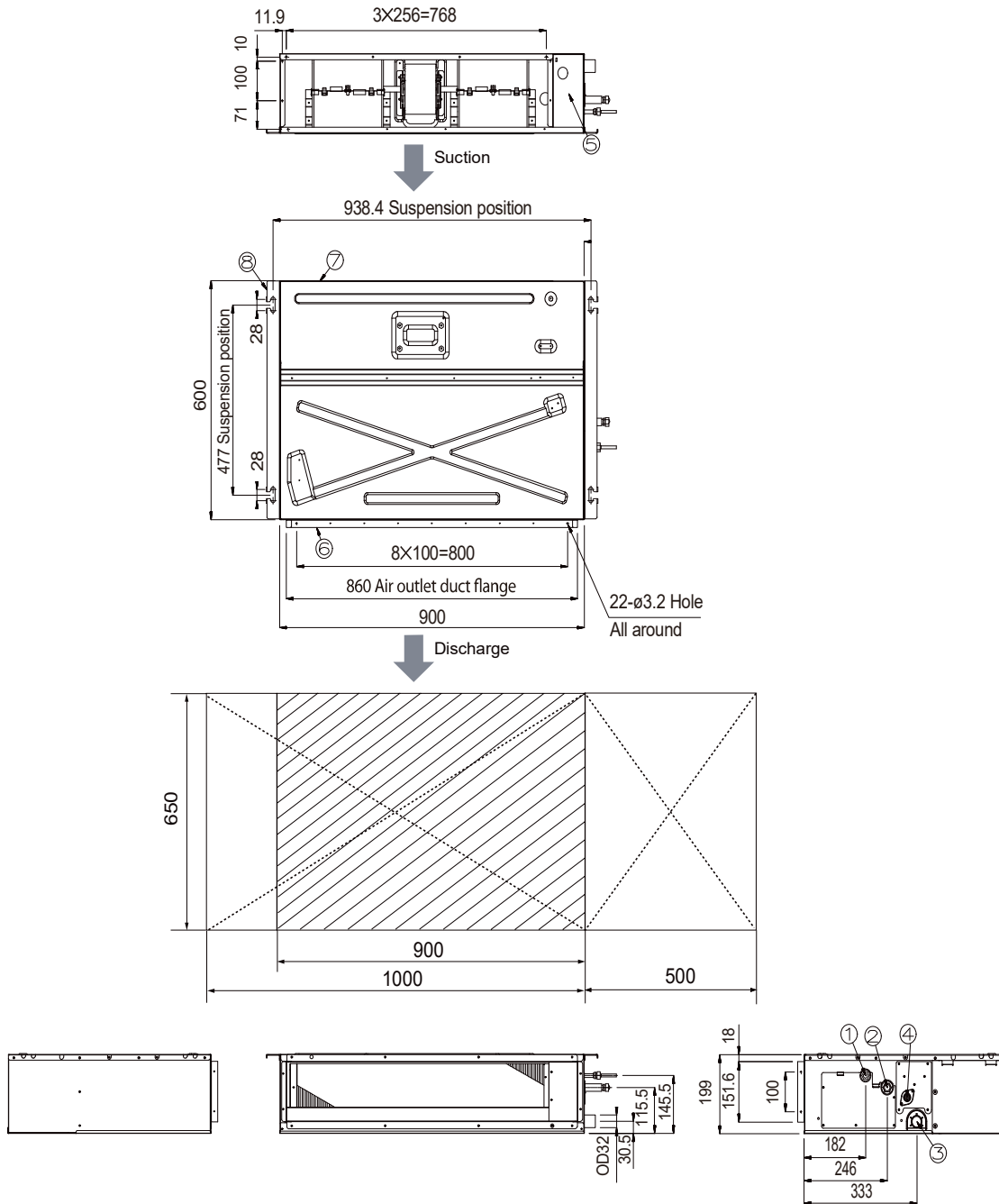

No.	Name	Description	
		4.5kW	5.6kW
①	Liquid pipe connection	Ø6.35 Flare	
②	Gas pipe connection	Ø12.70 Flare	
③	Drain pipe connection without drain pump	VP25 (OD 32, ID 25)	
④	Drain pipe connection with drain pump	VP25 (OD 32, ID 25)	
⑤	Power supply/Communication connection	-	
⑥	Air discharge grille flange	-	
⑦	Return air side	-	
⑧	Hook	-	

3 Dimensional Drawing

Slim Duct

AM071*NLDEH/EU

[Unit : mm]

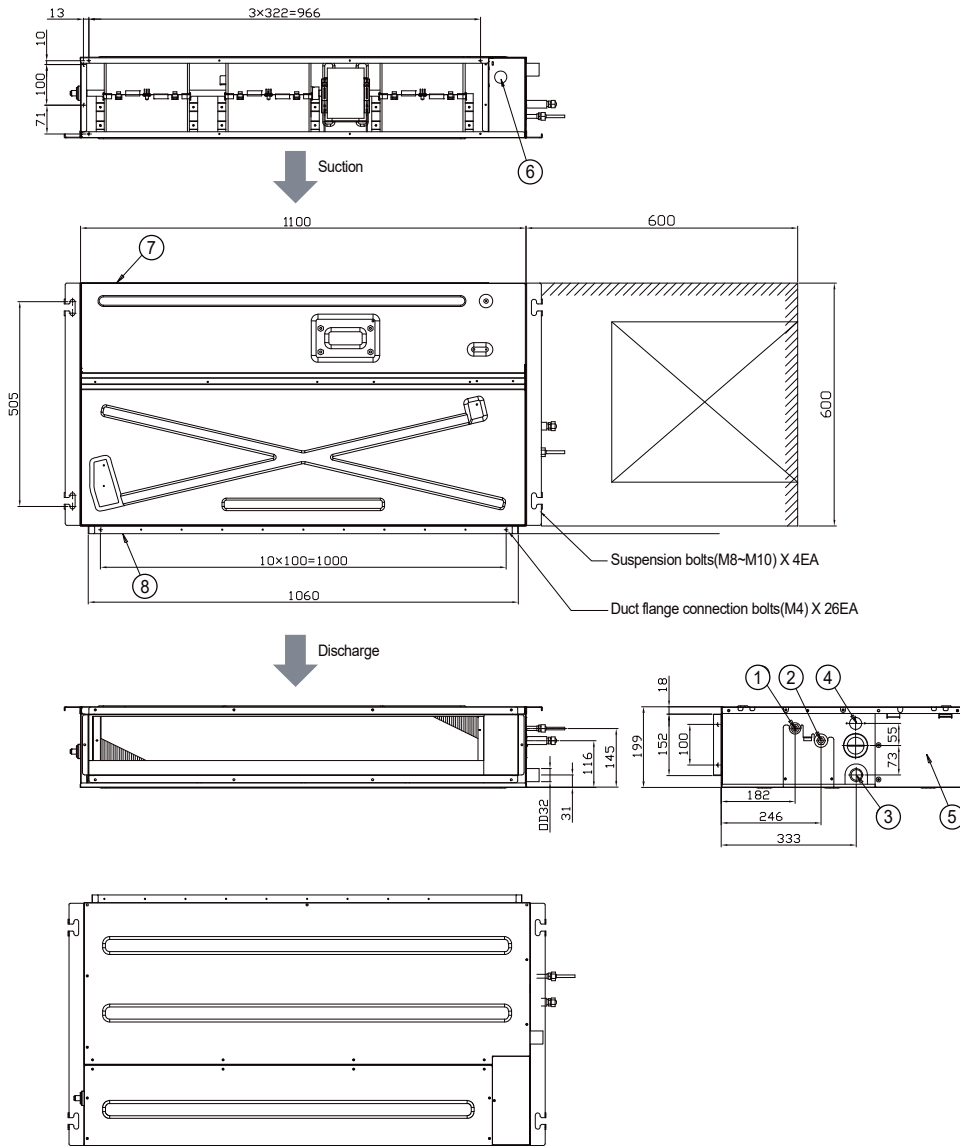

No.	Name	Description
		7.1kW
①	Liquid pipe connection	Ø9.52 Flare
②	Gas pipe connection	Ø15.88 Flare
③	Drain pipe connection without drain pump	VP25 (OD 32, ID 25)
④	Drain pipe connection with drain pump	VP25 (OD 32, ID 25)
⑤	Control unit	
⑥	Conduit for power supply & communication wiring	
⑦	Return air side	
⑧	Air outlet duct flange	

3 Dimensional Drawing

Slim Duct

AM090/112/128/140*NLDEH/EU

[Unit : mm]

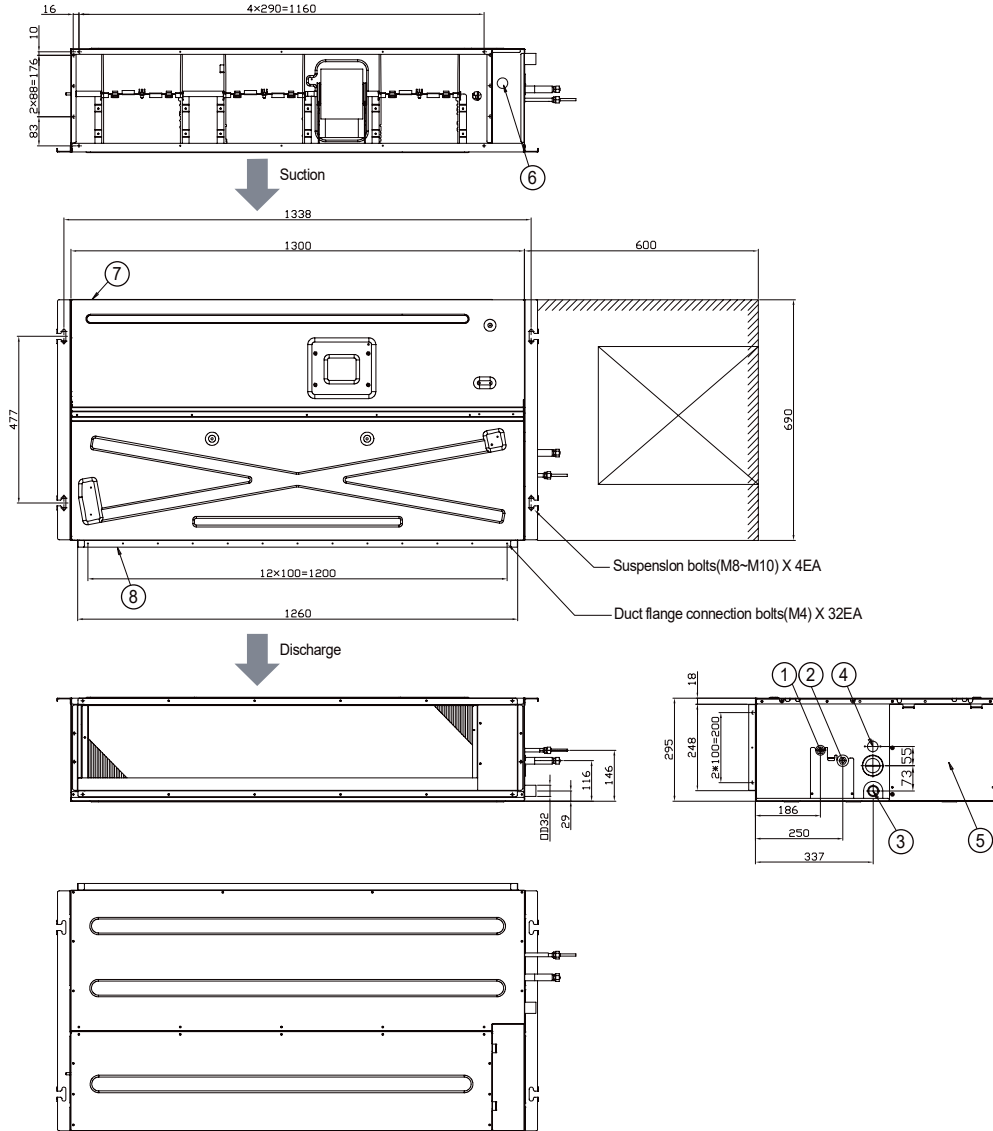

No.	Name	Description			
		9.0kW	11.2kW	12.8kW	14.0kW
①	Liquid pipe connection	Ø9.52 Flare			
②	Gas pipe connection	Ø15.88 Flare			
③	Drain pipe connection without drain pump	VP25 (OD 32, ID 25)			
④	Drain pipe connection with drain pump	VP25 (OD 32, ID 25)			
⑤	Control unit	-			
⑥	Conduit for power supply & communication wiring	-			
⑦	Return air side	-			
⑧	Air outlet duct flange	-			

4 Electrical Wiring Diagram

Slim Duct

AM017/022/028/036/045/056/071FNLDEH/EU, AM045/056/071KNLDEH/EU

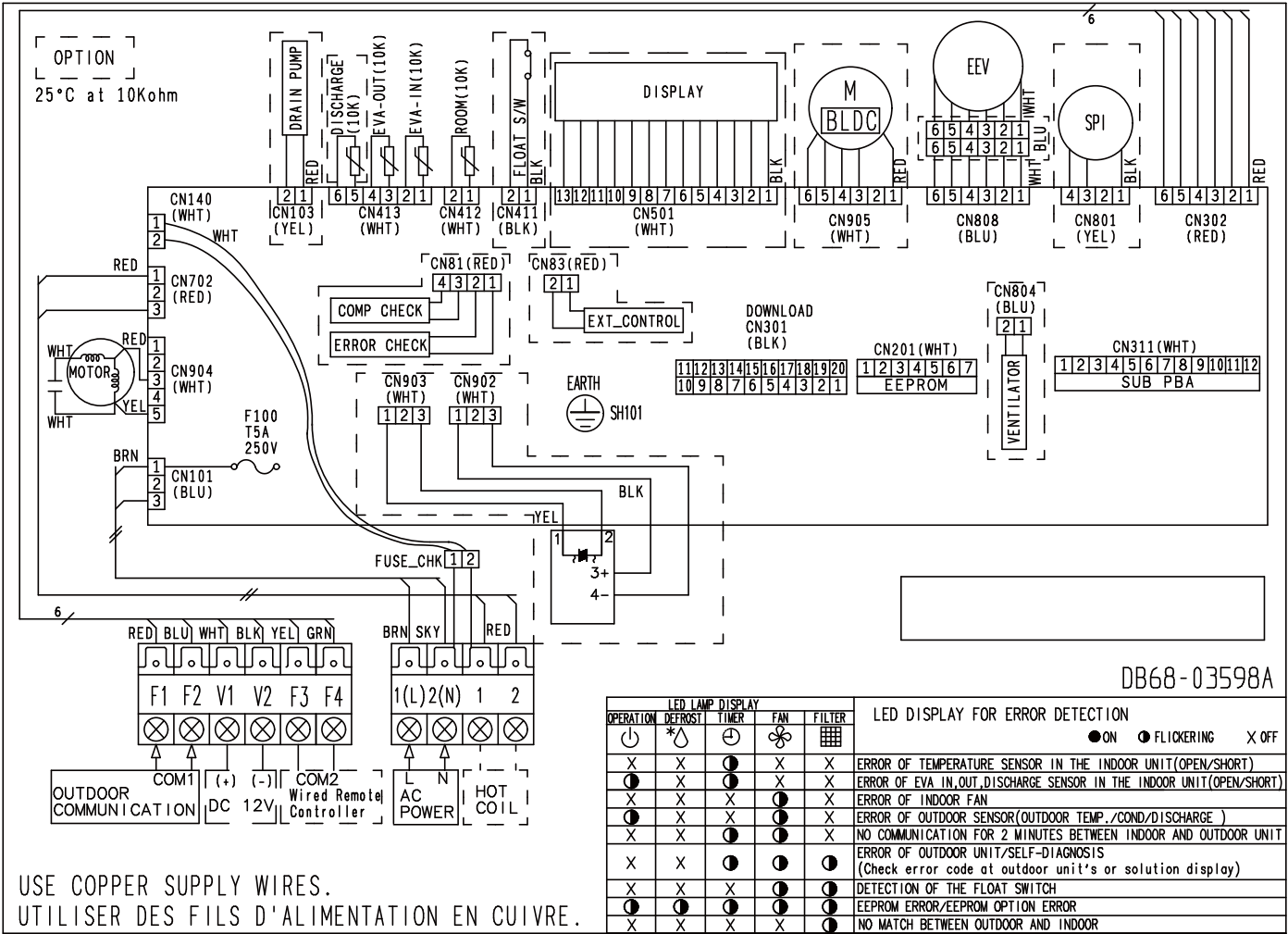

DB68-03598A

ROOM(10K)	Thermistor ROOM(10K)	EEV	electronic expansion valve	EVA-IN(10K)	Thermistor EVA IN(10K)
DISCHARGE(10K)	Thermistor DISCHARGE(10K)	SPI	S-Plasma ion	EVA-OUT(10K)	Thermistor EVA OUT(10K)

NOTE

- This wiring diagram applies only to the indoor unit.
- Symbols show as follow;
BLK : black, RED : red, BLU : blue, WHT:white, YEL : yellow, BRN : brown, SKY : sky-blue, GRN : green
- For connection wiring indoor-outdoor transmission F1-F2, indoor-wired remotecontroller transmission F3-F4.
- ⊕: Protective earth(screw), □□□□: Connector, n: The wire quantity

4 Electrical Wiring Diagram

Slim Duct / Slim Duct Home

AM090/112/128/140FNLDEH/EU, AM017/022/028/036/090/112/128/140KNLDEH/EU

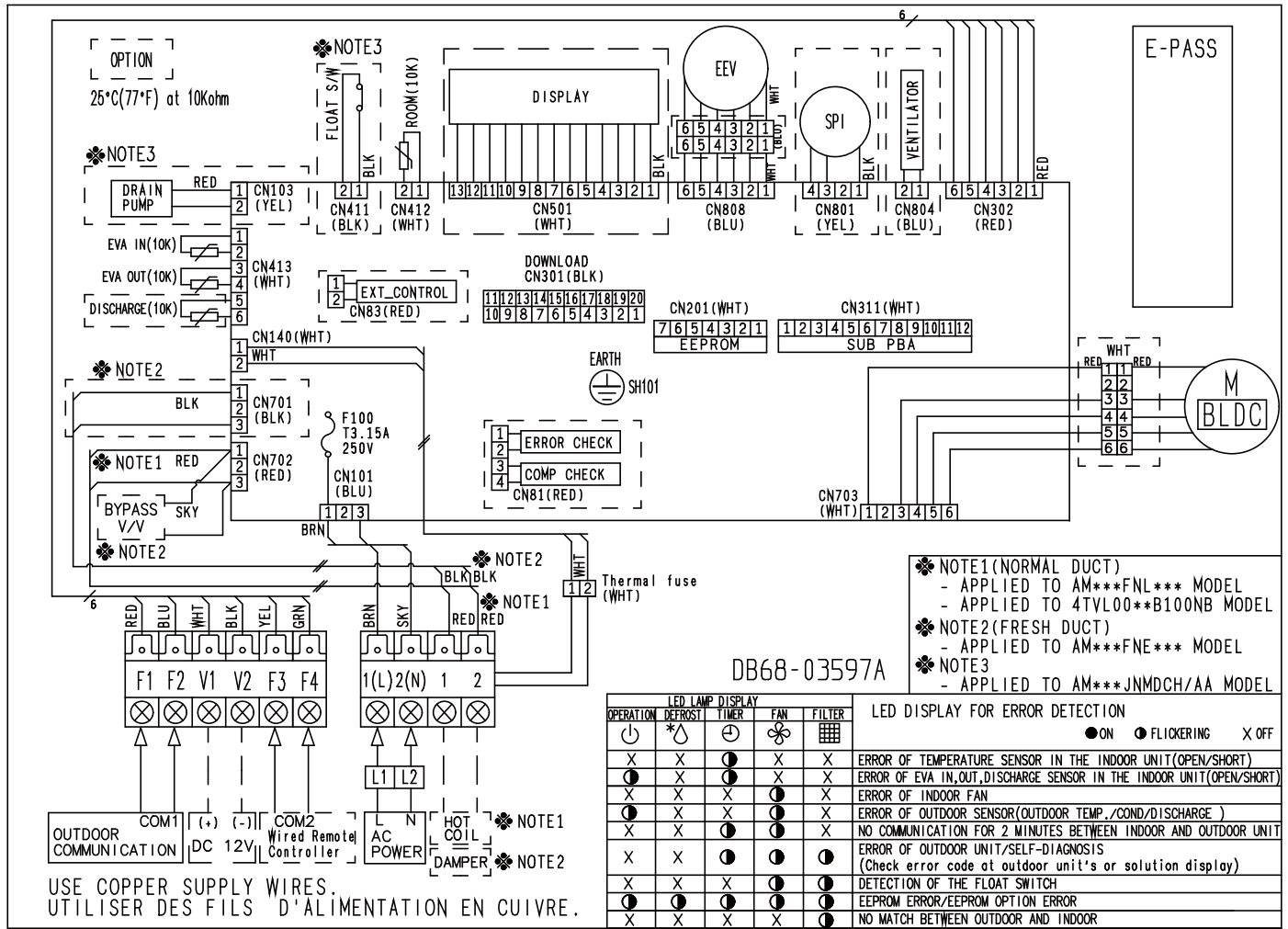

M [BLDC]	Motor (BLDC)	EEV	electronic expansion valve	EVA-IN(10K)	Thermistor EVA IN(10K)
DISCHARGE(10K)	Thermistor DISCHARGE(10K)	SPI	S-Plasma ion	EVA-OUT(10K)	Thermistor EVA OUT(10K)

NOTE

- This wiring diagram applies only to the indoor unit.
- Symbols show as follow;
 BLK : black, RED : red, BLU : blue, WHT: white, YEL : yellow, BRN : brown, SKY : sky-blue, GRN : green
- For connection wiring indoor-outdoor transmission F1-F2, indoor-wired remotecontroller transmission F3-F4.
- ⊕: Protective earth(screw), □□□□: Connector, n: The wire quantity

5 Sound Pressure Level

Slim Duct

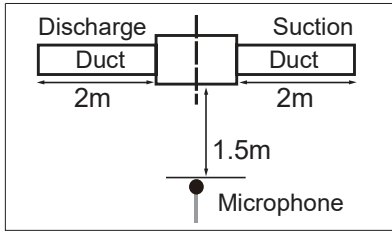

Unit: dB(A)

Model	High	Low
AM017FNLDEH/EU	23	20
AM022FNLDEH/EU	26	21
AM028FNLDEH/EU	28	23
AM036FNLDEH/EU	32	27

Note

Specifications may be subject to change without prior notice.
 Sound pressure level is obtained in an anechoic room.
 Sound pressure level is a relative value, depending on the distance and acoustic environment.
 Sound pressure level may differ depending on operation condition.
 dBA = A-weighted sound pressure level
 Reference acoustic pressure 0 dB= 20 uPa

NR curve

1) AM017FNLDEH/EU

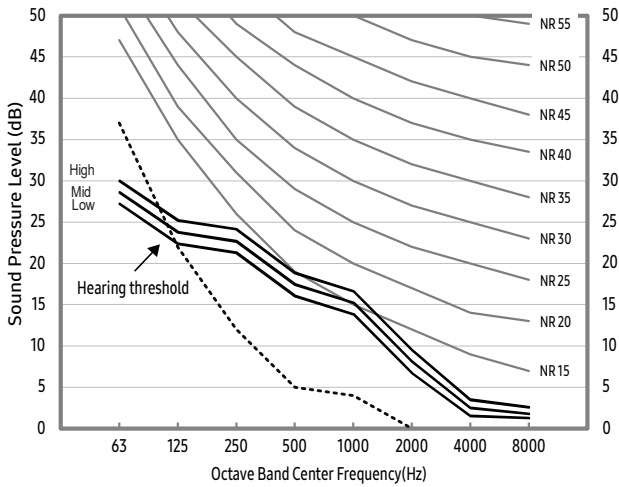

2) AM022FNLDEH/EU

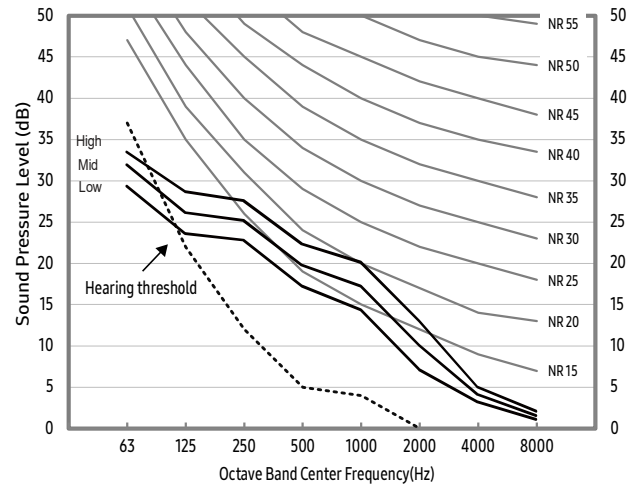

3) AM028FNLDEH/EU

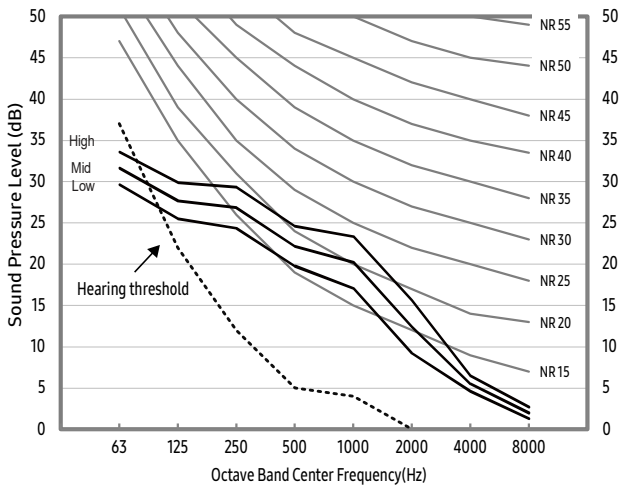

4) AM036FNLDEH/EU

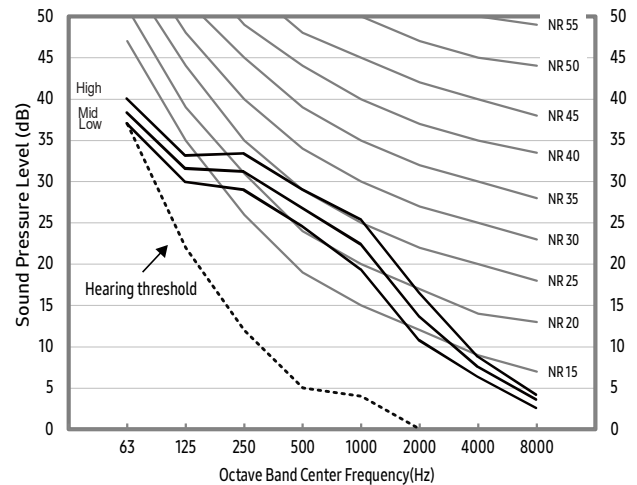

5 Sound Pressure Level

Slim Duct (Home)

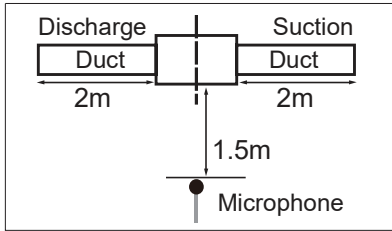

Model	Unit: dB(A)	
	High	Low
AM017KNLDEH/EU	25	19
AM022KNLDEH/EU	26	19
AM028KNLDEH/EU	28	19
AM036KNLDEH/EU	31	20

Note

Specifications may be subject to change without prior notice.
 Sound pressure level is obtained in an anechoic room.
 Sound pressure level is a relative value, depending on the distance and acoustic environment.
 Sound pressure level may differ depending on operation condition.
 dBA = A-weighted sound pressure level
 Reference acoustic pressure 0 dB= 20 uPa

NR curve

1) AM017KNLDEH/EU

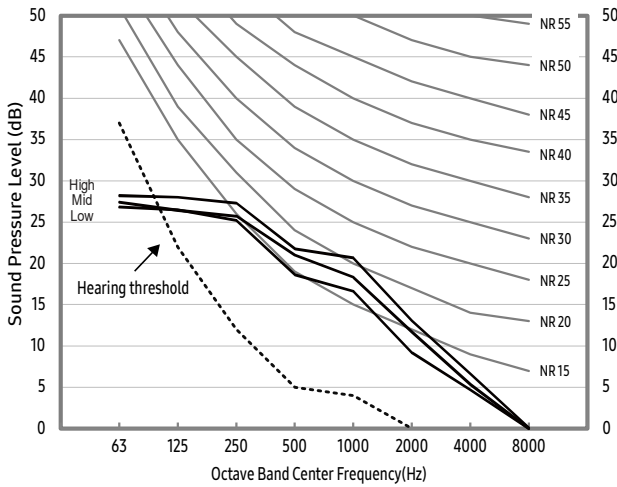

2) AM022KNLDEH/EU

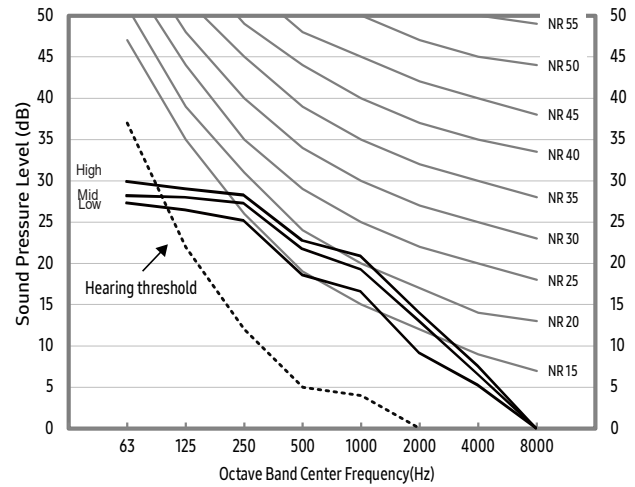

3) AM028KNLDEH/EU

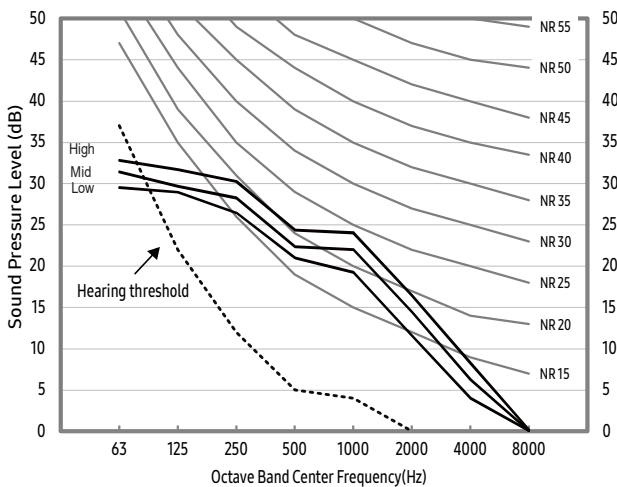

4) AM036KNLDEH/EU

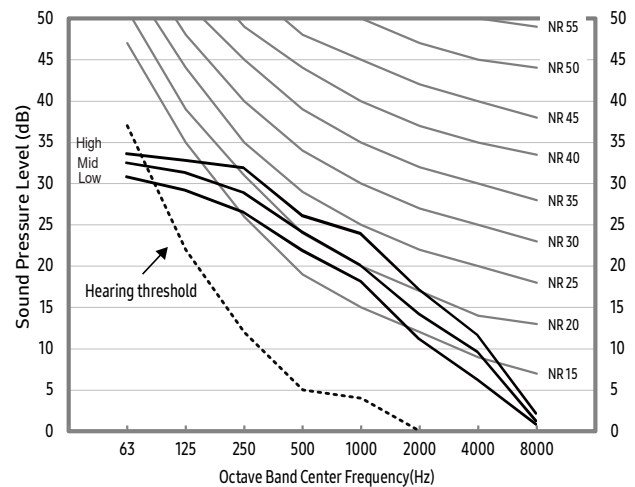

5 Sound Pressure Level

Slim Duct

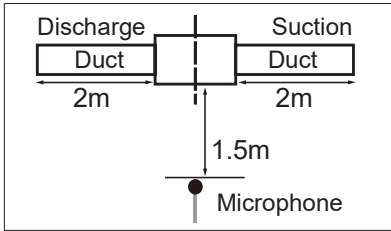

Model	Unit: dB(A)	
	High	Low
AM045*NLDEH***	35	26
AM056*NLDEH***	36	31
AM071*NLDEH***	38	33
AM090*NLDEH***	37	34

Note

Specifications may be subject to change without prior notice.
 Sound pressure level is obtained in an anechoic room.
 Sound pressure level is a relative value, depending on the distance and acoustic environment.
 Sound pressure level may differ depending on operation condition.
 dBA = A-weighted sound pressure level
 Reference acoustic pressure 0 dB= 20 uPa

NR curve

1) AM045*NLDEH***

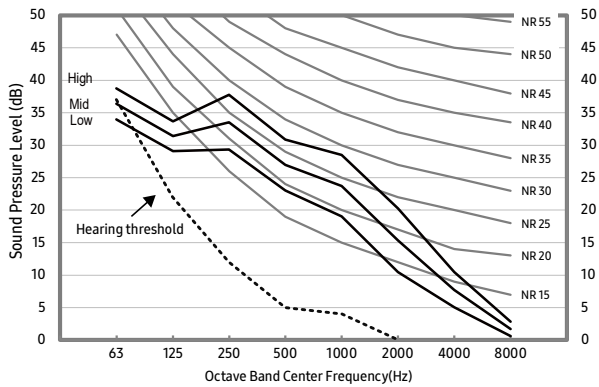

2) AM056*NLDEH***

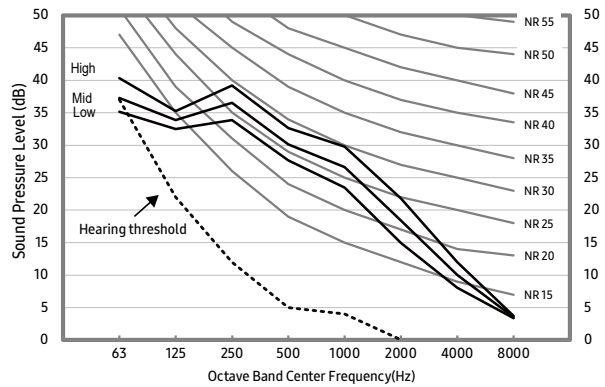

3) AM071*NLDEH***

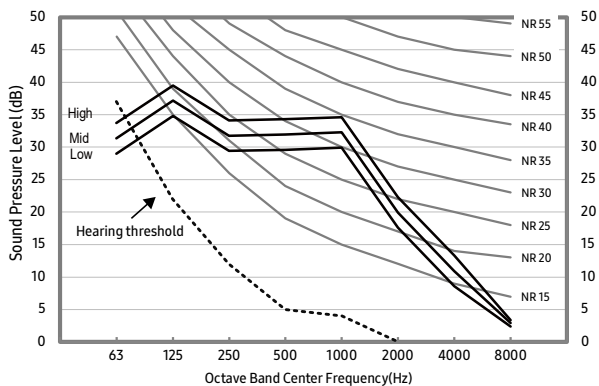

4) AM090*NLDEH***

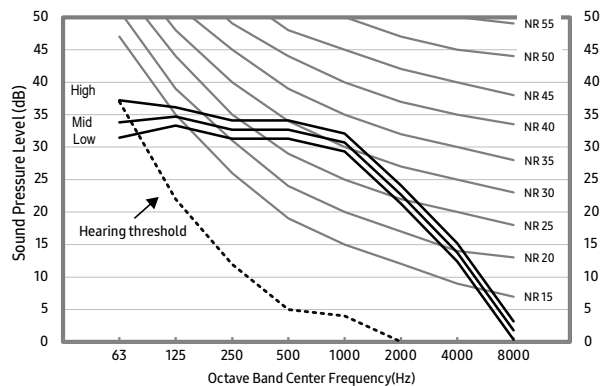

5 Sound Pressure Level

Slim Duct

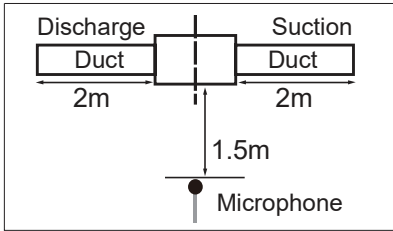

Model	Unit: dB(A)	
	High	Low
AM112*NLDEH***	37	34
AM128*NLDEH***	37	34
AM140*NLDEH***	39	36

Note

Specifications may be subject to change without prior notice.
 Sound pressure level is obtained in an anechoic room.
 Sound pressure level is a relative value, depending on the distance and acoustic environment.
 Sound pressure level may differ depending on operation condition.
 dBA = A-weighted sound pressure level
 Reference acoustic pressure 0 dB= 20 uPa

NR curve

5) AM112*NLDEH***

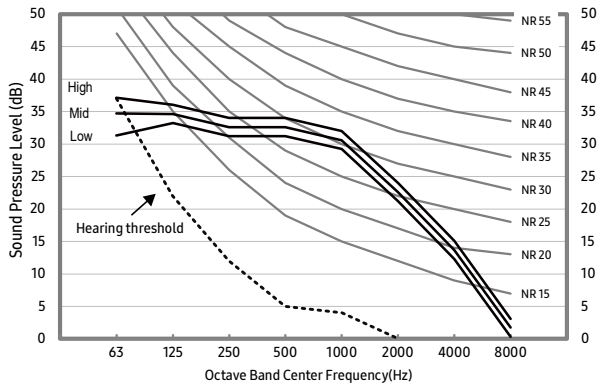

6) AM128*NLDEH***

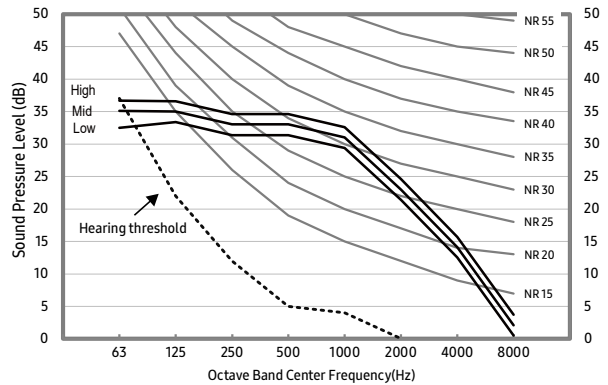

7) AM140*NLDEH***

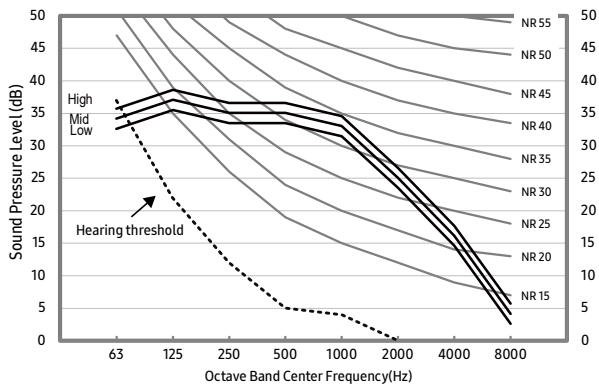

6 Sound Power Level

Slim Duct

Unit: dB(A)

Model	Power
AM017FNLDEH/EU	49
AM022FNLDEH/EU	49
AM028FNLDEH/EU	49
AM036FNLDEH/EU	51

Note

- . Specifications may be subject to change without prior notice.
- . Sound power level is an absolute value that a sound source generates.
- . dBA = A-weighted sound power level.
- . Reference power : 1pW.
- . Measured according to ISO 3741

1) AM017FNLDEH/EU

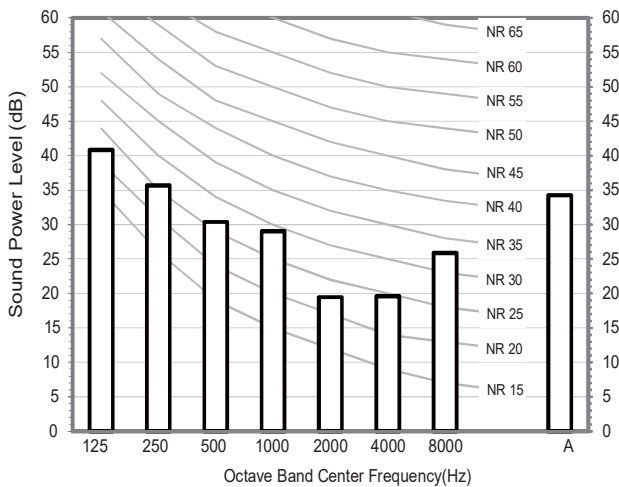

2) AM022FNLDEH/EU

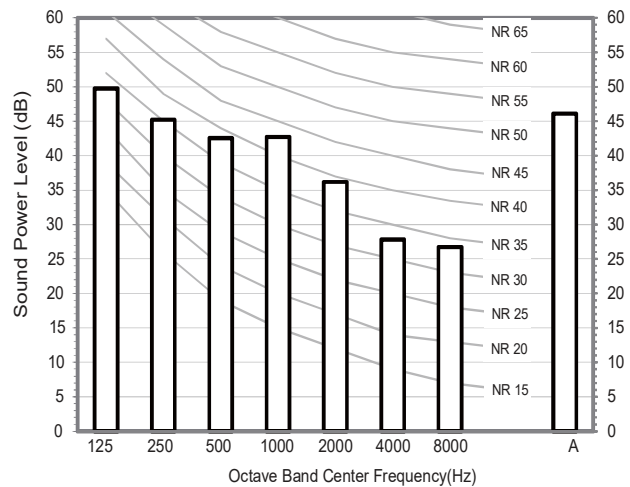

3) AM028FNLDEH/EU

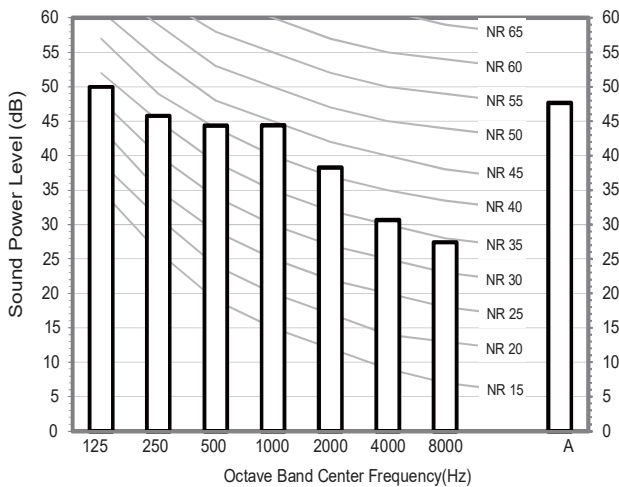

4) AM036FNLDEH/EU

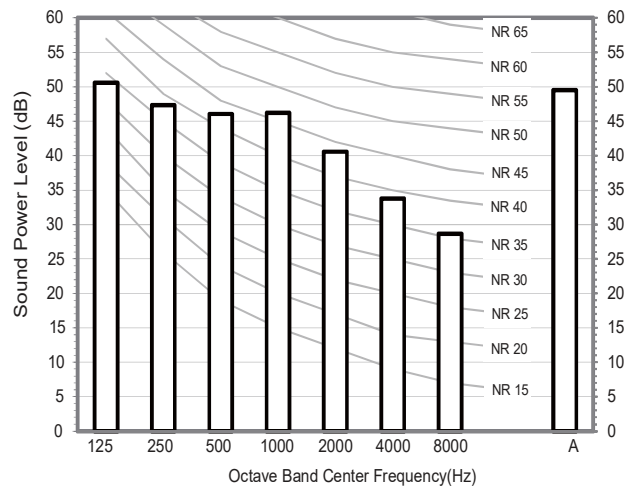

6 Sound Power Level

Slim Duct (Home)

Unit: dB(A)

Model	Power
AM017KNLDEH/EU	40
AM022KNLDEH/EU	42
AM028KNLDEH/EU	44
AM036KNLDEH/EU	46

Note

- . Specifications may be subject to change without prior notice.
- . Sound power level is an absolute value that a sound source generates.
- . dBA = A-weighted sound power level.
- . Reference power : 1pW.
- . Measured according to ISO 3741

1) AM017KNLDEH/EU

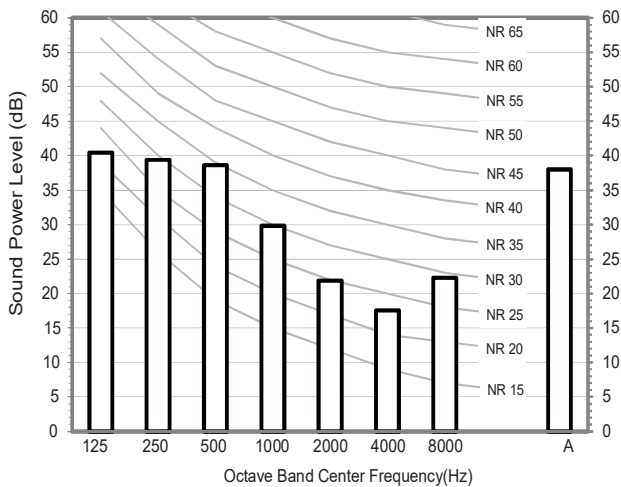

2) AM022KNLDEH/EU

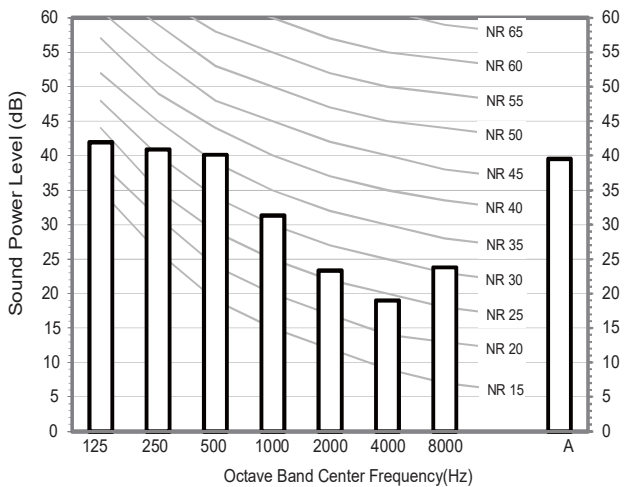

3) AM028KNLDEH/EU

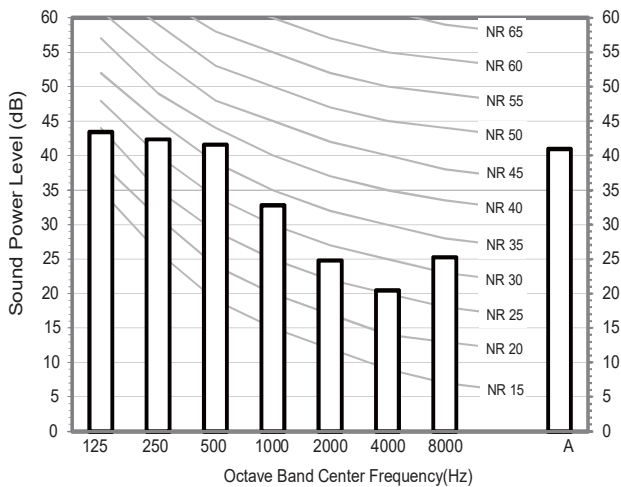

4) AM036KNLDEH/EU

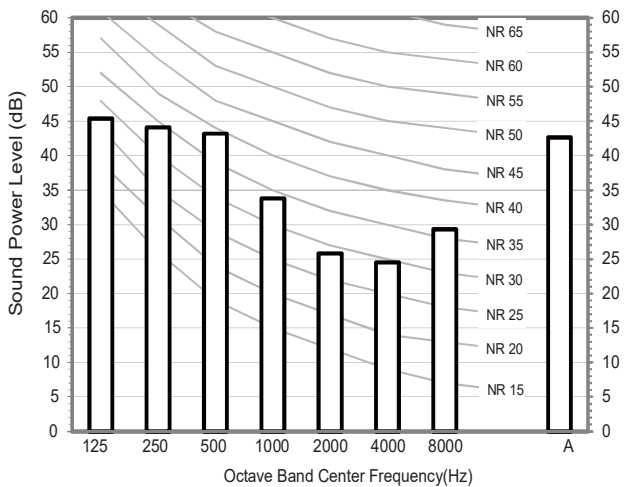

6 Sound Power Level

Slim Duct

Unit: dB(A)

Model	Power
AM045*NLDEH/EU	53
AM056*NLDEH/EU	55
AM071*NLDEH/EU	57
AM090*NLDEH/EU	66

Note

- . Specifications may be subject to change without prior notice.
- . Sound power level is an absolute value that a sound source generates.
- . dBA = A-weighted sound power level.
- . Reference power : 1pW.
- . Measured according to ISO 3741

1) AM045*NLDEH***

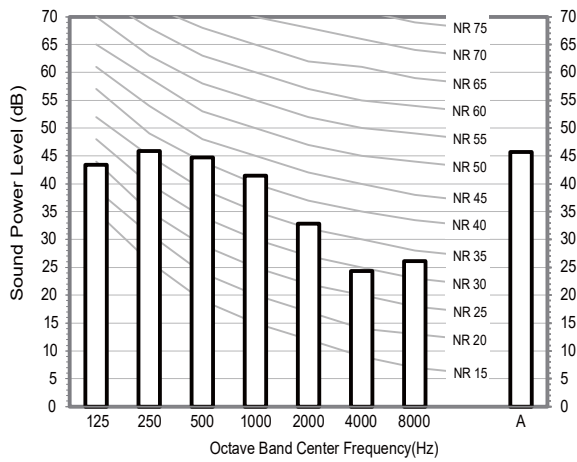

2) AM056*NLDEH***

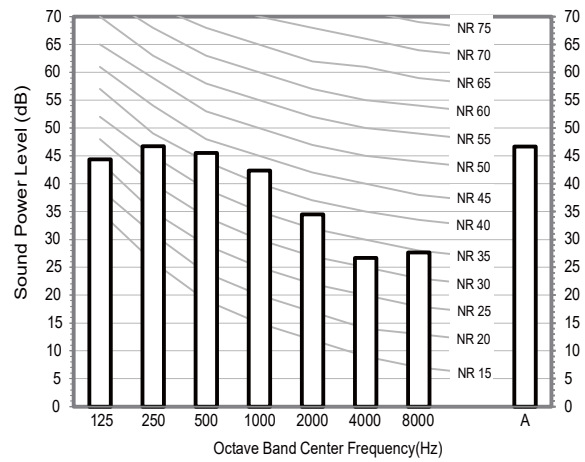

3) AM071*NLDEH***

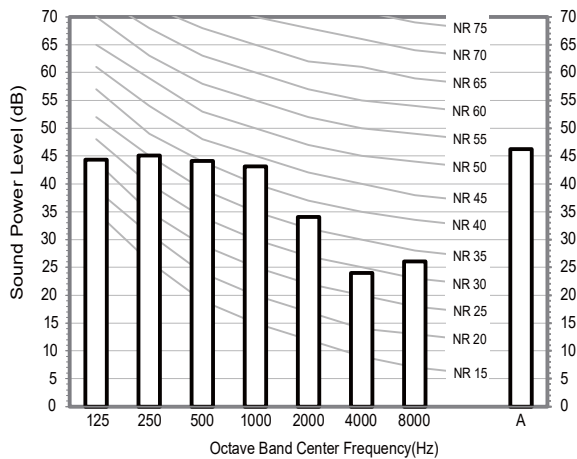

4) AM090*NLDEH***

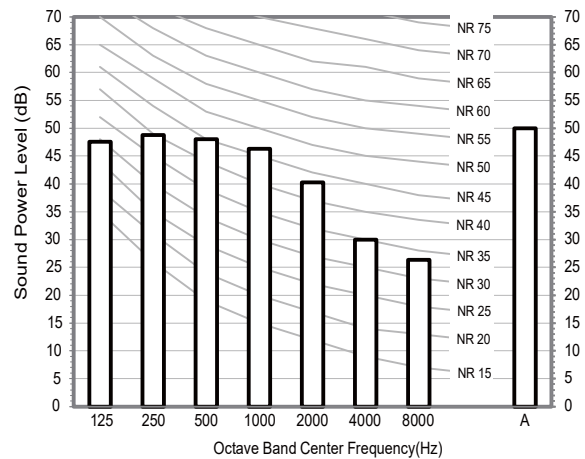

6 Sound Power Level

Slim Duct

Unit: dB(A)

Model	Power
AM112*NLDEH/EU	66
AM128*NLDEH/EU	66
AM140*NLDEH/EU	68

Note

- . Specifications may be subject to change without prior notice.
- . Sound power level is an absolute value that a sound source generates.
- . dBA = A-weighted sound power level.
- . Reference power : 1pW.
- . Measured according to ISO 3741

5) AM112*NLDEH***

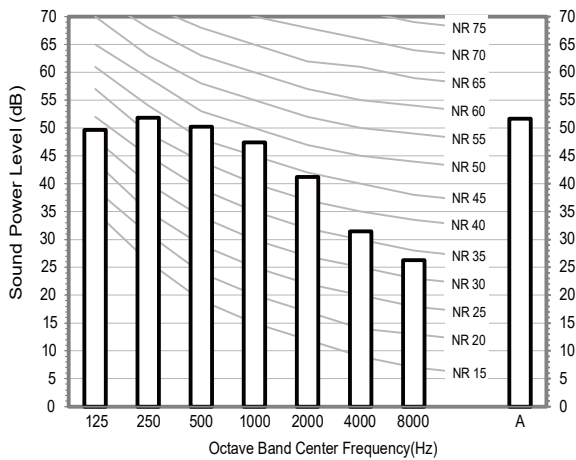

6) AM128*NLDEH***

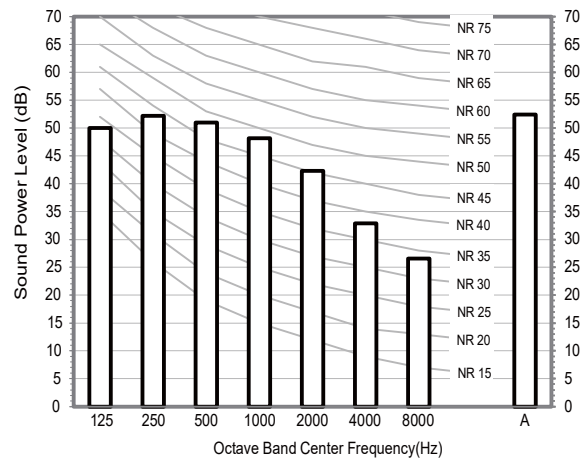

7) AM140*NLDEH***

