

2Way Cassette

- 1 *Specifications*
- 2 *Capacity Table*
- 3 *Dimensional Drawing*
- 4 *Electrical Wiring Diagram*
- 5 *Sound Pressure Level*
- 6 *Temperature and air flow distribution*

1 Specifications

2Way Cassette

1) Technical specifications

Model				AM056FN2DEH***	AM071FN2DEH***	
Power Supply			Ø, #, V, Hz	1, 2, 220-240, 50	1, 2, 220-240, 50	
Mode* ¹⁾			-	HP/HR	HP/HR	
Performance	Capacity (Nominal)	Cooling* ²⁾	kW	5.6	7.1	
			Btu/h	19,100	24,200	
		Heating* ³⁾	kW	6.3	8.0	
			Btu/h	21,500	27,300	
Power	Power Input (Nominal)	Cooling* ²⁾	W	70	75	
		Heating* ³⁾	W	70	75	
	Current Input (Nominal)	Cooling* ²⁾	A	0.38	0.40	
		Heating* ³⁾	A	0.38	0.40	
Fan	Motor	Type	-	Crossflow Fan	Crossflow Fan	
		Output	W	14	14	
		Number of unit	EA	2	2	
	Air Flow Rate	H/M/L (UL)	CMM		14 / 13 / 12	15 / 14 / 13
			l/s		233.33/216.67/200.00	250.00/233.33/216.67
	External Pressure	Min / Std / Max	mmAq		-	-
			Pa		-	-
WG				-	-	
Option Code			-	012044-115561-203838-330010	012044-115582-204747-330010	
Piping Connections	Liquid Pipe	Ø, mm		6.35	9.52	
		Ø, inch		1/4	3/8	
	Gas Pipe	Ø, mm		12.70	15.88	
		Ø, inch		1/2	5/8	
	Drain Pipe	Ø, mm		VP25 (OD 32, ID 25)	VP25 (OD 32, ID 25)	
Field Wiring	Power Source Wire	Below 20m / over 20m	mm ²	1.5 / 2.5	1.5 / 2.5	
	Transmission Cable		mm ²	0.75-1.5	0.75-1.5	
Refrigerant	Type	-	-	R410A	R410A	
	Control Method	-	-	EEV INCLUDED	EEV INCLUDED	
Sound	Sound Pressure	High / Mid / Low ⁴⁾	dBA	38 / 37 / 35	41 / 39 / 37	
Dimensions	Net Weight		kg	21.00	22.00	
	Shipping Weight		kg	25.00	26.00	
	Net Dimensions (WxHxD)		mm	890 x 230 x 575	890 x 230 x 575	
	Shipping Dimensions (WxHxD)		mm	1,077 x 299 x 642	1,077 x 299 x 642	
Panel Size	Panel model		-	PC2NUSMEN	PC2NUSMEN	
	Panel Net Weight		kg	4.00	4.00	
	Shipping Weight		kg	8.00	8.00	
	Net Dimensions (WxHxD)		mm	1030 x 25 x 650	1030 x 25 x 650	
	Shipping Dimensions (WxHxD)		mm	1103 x 151 x 727	1103 x 151 x 727	
Additional Accessories	Drain pump	Drain pump	- / Model	Built-in	Built-in	
		Max. lifting Height / Displacement	mm/liter/h	750 / 24	750 / 24	
	Air Filter		-	-	Long life filter	Long life filter

* Specifications may be subject to change without prior notice for product improvement.

*1) Mode

- HP : Heat Pump, HR : Heat Recovery

*2) Nominal cooling capacities are based on;

- Indoor temperature : 27°C DB, 19°C WB

- Outdoor temperature : 35°C DB, 24°C WB, Equivalent refrigerant piping : 7.5m, Level differences : 0m

*3) Nominal heating capacities are based on;

- Indoor temperature : 20°C DB, 15°C WB

- Outdoor temperature : 7°C DB, 6°C WB, Equivalent refrigerant piping : 7.5m, Level differences : 0m

*4) Sound pressure was acquired in an anechoic room. Thus actual noise level may be different depending on the installation conditions.

*5) These products contain R410A which is fluorinated greenhouse gas.

* Heat Exchanger type : Fin & Tube (Fin : Al, Tube : Cu)

2 Capacity table

2Way Cassette

1) Cooling

TC : Total Capacity(kW), SHC : Sensible Heat Capacity(kW)

Capacity Index	Outdoor Air Temp. (°C, DB)	Indoor temperature													
		20(°C, DB)		23(°C, DB)		26(°C, DB)		27(°C, DB)		28(°C, DB)		30(°C, DB)		32(°C, DB)	
		14(°C, WB)		16(°C, WB)		18(°C, WB)		19(°C, WB)		20(°C, WB)		22(°C, WB)		24(°C, WB)	
		TC	SHC	TC	SHC	TC	SHC	TC	SHC	TC	SHC	TC	SHC	TC	SHC
056	10	3.9	3.2	4.6	3.5	5.3	3.9	5.6	3.9	5.8	3.9	6.3	3.9	6.7	3.7
	12	3.9	3.2	4.6	3.5	5.3	3.9	5.6	3.9	5.8	3.9	6.3	3.9	6.7	3.7
	14	3.9	3.2	4.6	3.5	5.3	3.9	5.6	3.9	5.8	3.9	6.2	3.8	6.7	3.7
	16	3.9	3.2	4.6	3.5	5.3	3.9	5.6	3.9	5.8	3.9	6.2	3.8	6.6	3.6
	18	3.9	3.2	4.6	3.5	5.3	3.9	5.6	3.9	5.8	3.9	6.2	3.8	6.6	3.6
	20	3.9	3.2	4.6	3.5	5.3	3.9	5.6	3.9	5.8	3.9	6.2	3.8	6.6	3.6
	21	3.9	3.2	4.6	3.5	5.3	3.9	5.6	3.9	5.8	3.9	6.2	3.8	6.6	3.6
	23	3.9	3.2	4.6	3.5	5.3	3.9	5.6	3.9	5.8	3.9	6.2	3.8	6.6	3.6
	25	3.9	3.2	4.6	3.5	5.3	3.9	5.6	3.9	5.8	3.9	6.2	3.8	6.6	3.6
	27	3.9	3.2	4.6	3.5	5.3	3.9	5.6	3.9	5.8	3.9	6.2	3.8	6.6	3.6
	29	3.9	3.2	4.6	3.5	5.3	3.9	5.6	3.9	5.8	3.9	6.2	3.8	6.6	3.6
	31	3.9	3.2	4.6	3.5	5.3	3.9	5.6	3.9	5.8	3.9	6.2	3.8	6.6	3.6
	33	3.9	3.2	4.6	3.5	5.3	3.9	5.6	3.9	5.8	3.9	6.2	3.8	6.6	3.6
	35	3.9	3.2	4.6	3.5	5.3	3.9	5.6	3.9	5.8	3.9	6.2	3.8	6.6	3.6
	37	3.9	3.2	4.6	3.5	5.3	3.9	5.6	3.9	5.8	3.9	6.2	3.8	6.6	3.5
	39	3.9	3.2	4.6	3.5	5.3	3.9	5.6	3.9	5.8	3.9	6.2	3.8	6.6	3.4
42	3.9	3.2	4.6	3.5	5.3	3.9	5.5	3.8	5.7	3.9	6.1	3.7	6.4	3.3	
44	3.9	3.2	4.6	3.5	5.1	3.8	5.3	3.7	5.6	3.7	5.9	3.6	6.2	3.2	
46	3.9	3.2	4.6	3.5	5.0	3.7	5.2	3.6	5.4	3.6	5.7	3.5	6.0	3.1	
48	3.9	3.2	4.5	3.4	5.0	3.6	5.0	3.5	5.3	3.6	5.5	3.4	5.8	3.0	
071	10	4.9	4.0	5.8	4.5	6.7	4.8	7.1	5.0	7.4	5.0	8.0	5.1	8.5	4.8
	12	4.9	4.0	5.8	4.5	6.7	4.8	7.1	5.0	7.4	5.0	7.9	5.0	8.5	4.8
	14	4.9	4.0	5.8	4.5	6.7	4.8	7.1	5.0	7.4	5.0	7.9	5.0	8.5	4.8
	16	4.9	4.0	5.8	4.5	6.7	4.8	7.1	5.0	7.4	5.0	7.9	5.0	8.4	4.8
	18	4.9	4.0	5.8	4.5	6.7	4.8	7.1	5.0	7.4	5.0	7.9	5.0	8.4	4.8
	20	4.9	4.0	5.8	4.5	6.7	4.8	7.1	5.0	7.4	5.0	7.9	5.0	8.4	4.8
	21	4.9	4.0	5.8	4.5	6.7	4.8	7.1	5.0	7.4	5.0	7.9	5.0	8.4	4.8
	23	4.9	4.0	5.8	4.5	6.7	4.8	7.1	5.0	7.4	5.0	7.9	5.0	8.4	4.8
	25	4.9	4.0	5.8	4.5	6.7	4.8	7.1	5.0	7.4	5.0	7.9	5.0	8.4	4.8
	27	4.9	4.0	5.8	4.5	6.7	4.8	7.1	5.0	7.4	5.0	7.9	5.0	8.4	4.8
	29	4.9	4.0	5.8	4.5	6.7	4.8	7.1	5.0	7.4	5.0	7.9	5.0	8.4	4.8
	31	4.9	4.0	5.8	4.5	6.7	4.8	7.1	5.0	7.4	5.0	7.9	5.0	8.4	4.8
	33	4.9	4.0	5.8	4.5	6.7	4.8	7.1	5.0	7.4	5.0	7.9	5.0	8.4	4.8
	35	4.9	4.0	5.8	4.5	6.7	4.8	7.1	5.0	7.4	5.0	7.9	5.0	8.4	4.8
	37	4.9	4.0	5.8	4.5	6.7	4.8	7.1	5.0	7.3	4.9	7.8	4.9	8.2	4.7
	39	4.9	4.0	5.8	4.5	6.7	4.8	7.1	5.0	7.3	4.9	7.7	4.8	8.1	4.6
42	4.9	4.0	5.8	4.5	6.7	4.8	7.0	4.9	7.2	4.8	7.6	4.7	7.9	4.5	
44	4.9	4.0	5.8	4.5	6.5	4.6	6.8	4.8	7.0	4.7	7.3	4.5	7.6	4.3	
46	4.9	4.0	5.7	4.5	6.4	4.6	6.6	4.6	6.8	4.6	7.0	4.4	7.4	4.2	
48	4.8	3.9	5.7	4.4	6.3	4.5	6.4	4.5	6.7	4.5	6.8	4.3	7.2	4.1	

2 Capacity table

2Way Cassette

2) Heating

TC : Total Capacity(kW)

Capacity Index	Outdoor Air Temp. (°C)		Indoor temperature (°C,DB)				
			16(°C,DB)	18(°C,DB)	20(°C,DB)	22(°C,DB)	24(°C,DB)
	DB	WB	TC kW	TC kW	TC kW	TC kW	TC kW
056	-19.8	-20.0	3.9	3.8	3.8	3.7	3.7
	-18.8	-19.0	3.9	3.9	3.8	3.7	3.7
	-16.7	-17.0	4.0	4.0	3.9	3.8	3.8
	-14.7	-15.0	4.2	4.1	4.0	3.9	3.8
	-12.6	-13.0	4.4	4.3	4.2	4.1	4.0
	-10.5	-11.0	4.6	4.5	4.4	4.4	4.3
	-9.5	-10.0	4.7	4.6	4.6	4.5	4.4
	-8.5	-9.1	4.8	4.7	4.7	4.6	4.5
	-7.0	-7.6	4.9	4.8	4.8	4.7	4.5
	-5.0	-5.6	5.2	5.1	5.0	4.9	4.7
	-3.0	-3.7	5.4	5.3	5.3	5.1	4.9
	0.0	-0.7	5.7	5.6	5.5	5.3	5.0
	3.0	2.2	5.9	5.9	5.8	5.6	5.3
	5.0	4.1	6.2	6.1	6.0	5.7	5.3
	7.0	6.0	6.5	6.4	6.3	5.8	5.3
9.0	7.9	6.7	6.5	6.3	5.8	5.3	
11.0	9.8	6.9	6.6	6.3	5.8	5.3	
13.0	11.8	7.1	6.7	6.3	5.8	5.3	
15.0	13.7	7.3	6.8	6.3	5.8	5.3	
071	-19.8	-20.0	4.9	4.9	4.8	4.7	4.7
	-18.8	-19.0	5.0	4.9	4.8	4.7	4.7
	-16.7	-17.0	5.1	5.0	4.9	4.8	4.8
	-14.7	-15.0	5.3	5.2	5.1	4.9	4.8
	-12.6	-13.0	5.5	5.4	5.3	5.2	5.1
	-10.5	-11.0	5.8	5.7	5.6	5.5	5.5
	-9.5	-10.0	6.0	5.9	5.8	5.7	5.6
	-8.5	-9.1	6.1	6.0	5.9	5.8	5.7
	-7.0	-7.6	6.2	6.1	6.0	5.9	5.8
	-5.0	-5.6	6.5	6.5	6.4	6.2	6.0
	-3.0	-3.7	6.9	6.8	6.7	6.4	6.2
	0.0	-0.7	7.2	7.1	7.0	6.7	6.4
	3.0	2.2	7.6	7.5	7.3	7.1	6.8
	5.0	4.1	7.9	7.8	7.7	7.2	6.8
	7.0	6.0	8.2	8.1	8.0	7.4	6.8
9.0	7.9	8.5	8.2	8.0	7.4	6.8	
11.0	9.8	8.7	8.4	8.0	7.4	6.8	
13.0	11.8	9.0	8.5	8.0	7.4	6.8	
15.0	13.7	9.2	8.6	8.0	7.4	6.8	

3 Dimensional drawing

2Way Cassette

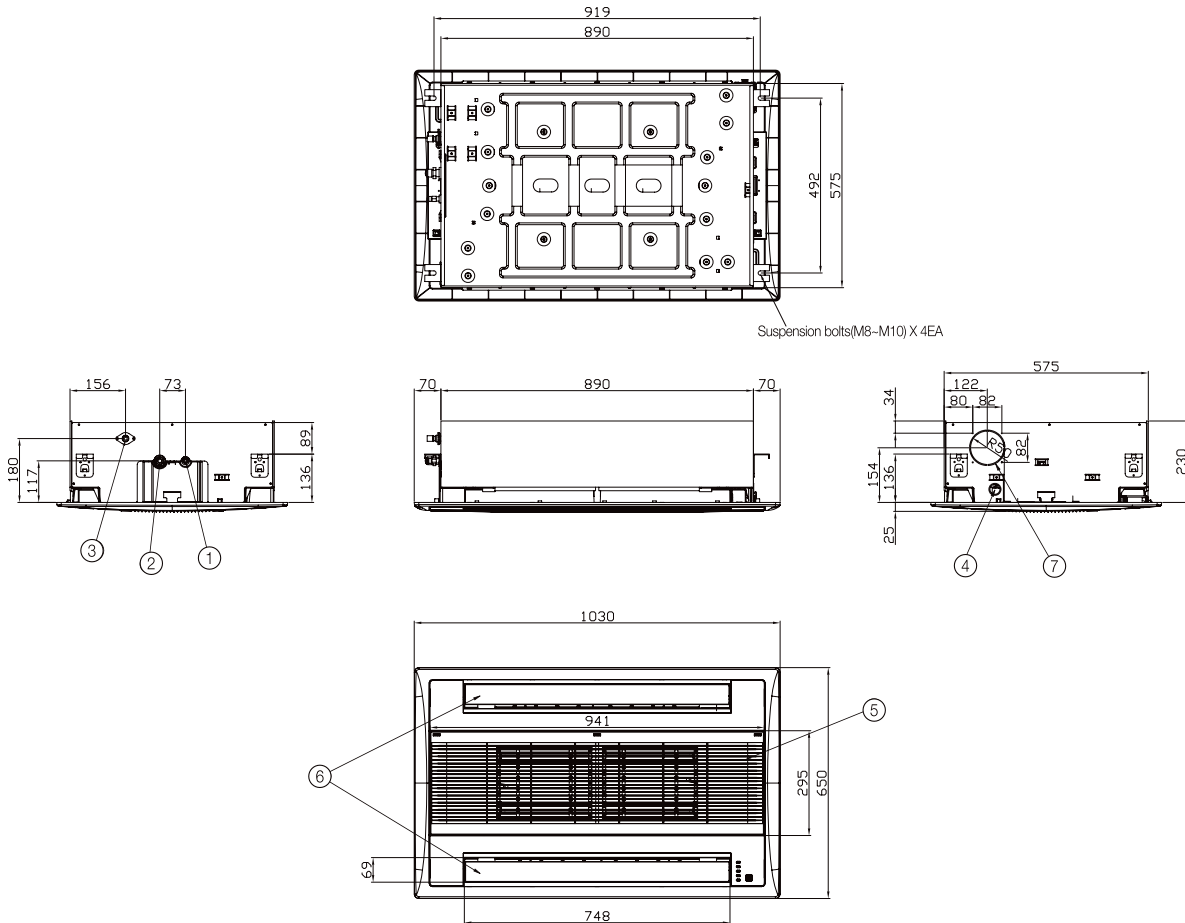

No.	Name	Description	
		5.6kW	7.1kW
①	Liquid pipe connection	Ø6.35 Flare	Ø9.52 Flare
②	Gas pipe connection	Ø12.70 Flare	Ø15.88 Flare
③	Drain pipe connection	VP25 (OD 32, ID 25)	
④	Conduit for power supply & communication wiring	-	
⑤	Air inlet grille	-	
⑥	Air outlet louver	-	
⑦	Fresh air intake	-	

4 Electrical wiring diagram

2Way Cassette

AM056FN2DEH/EU, AM071FN2DEH/EU

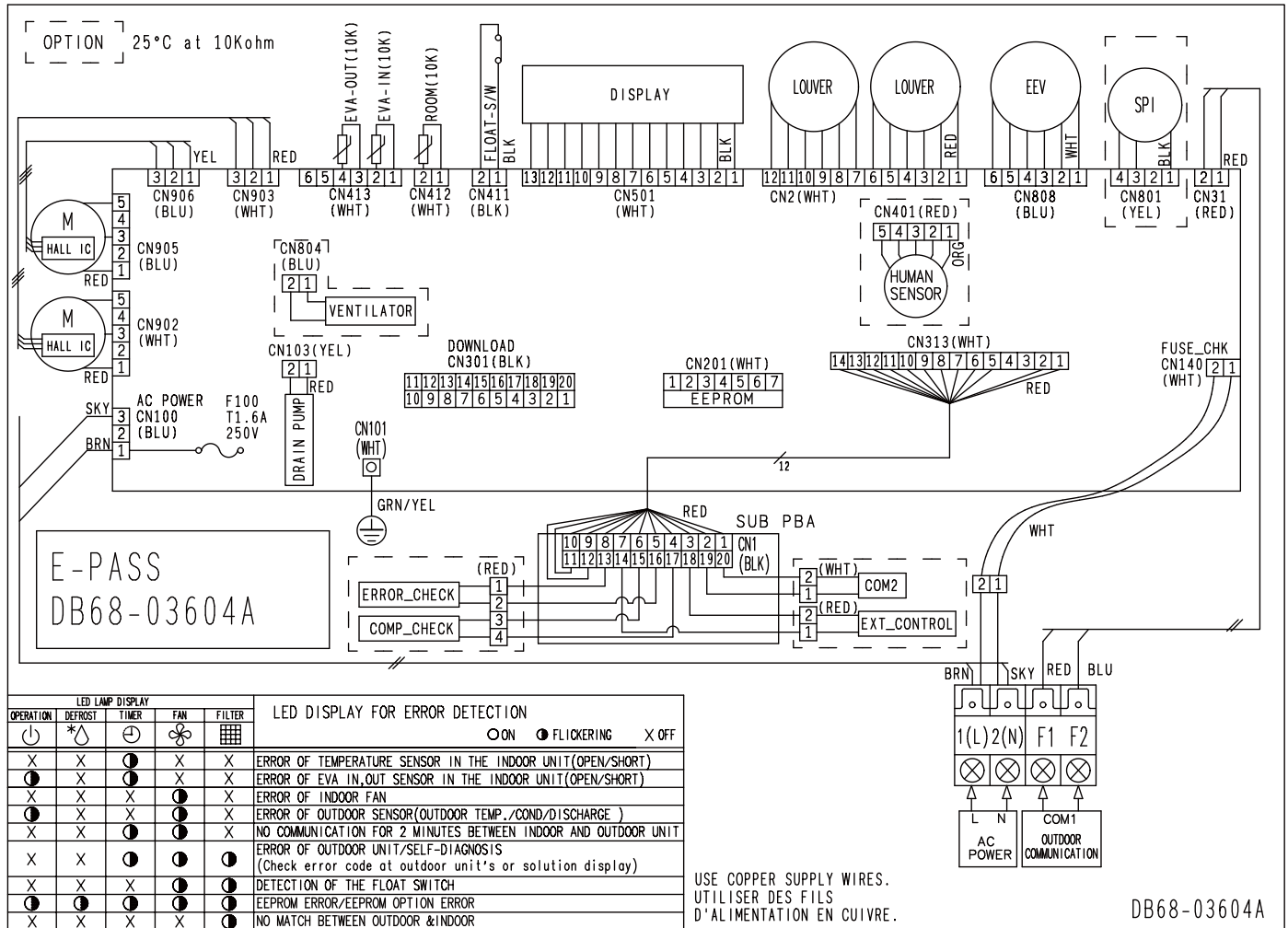

NOTE

1. This wiring diagram applies only to the indoor unit.
2. Symbols show as follow;
BLK : black, RED : red, BLU : blue, WHT:white, YEL : yellow, BRN : brown, SKY : sky-blue, GRN : green
3. For connection wiring indoor-outdoor transmission F1-F2, indoor-wired remotecontroller transmission F3-F4.
4. ⚡: Protective earth(screw), □□□□: Connector, n: The wire quantity

5 Sound pressure level

2Way Cassette

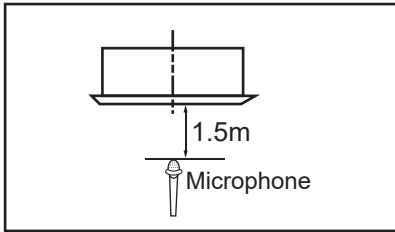

Unit: dB(A)

Model	High	Low
AM056FN2DEH/EU	38	35
AM071FN2DEH/EU	41	37

Note

Specifications may be subject to change without prior notice.
 Sound pressure level is obtained in an anechoic room.
 Sound pressure level is a relative value, depending on the distance and acoustic environment.
 Sound pressure level may differ depending on operation condition.
 dBA = A-weighted sound pressure level
 Reference acoustic pressure 0 dB= 20 uPa

NC curve

1) AM056FN2DEH/EU

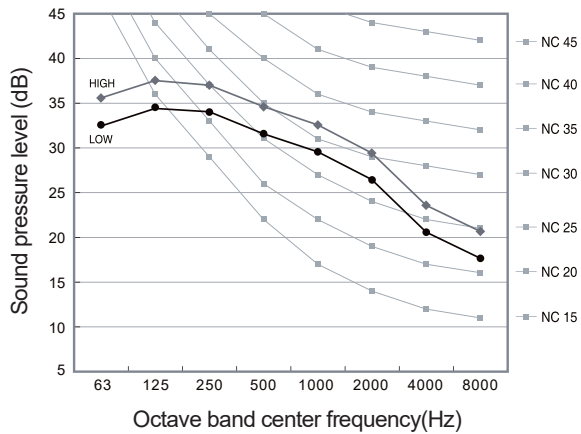

2) AM071FN2DEH/EU

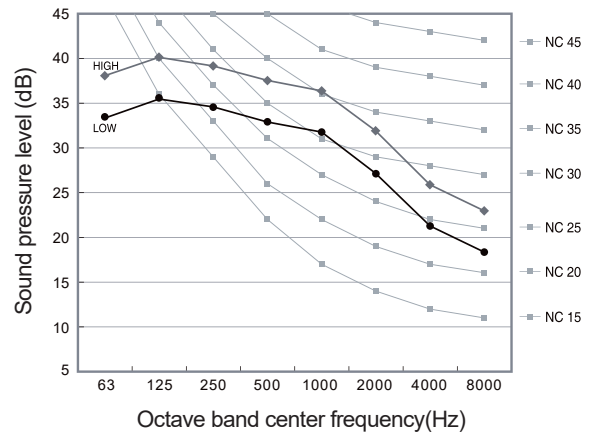

6 Temperature and air flow distribution

2Way Cassette

AM071FN2DEH/EU

(1) Cooling air velocity distribution

Discharge angle : 54°

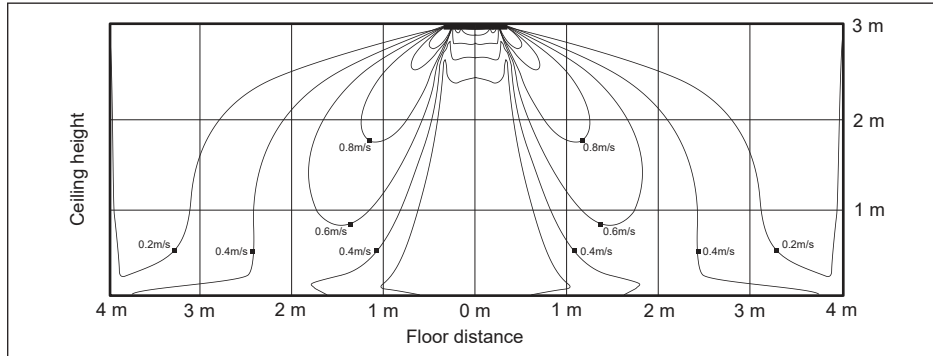

(2) Cooling temperature distribution

Discharge angle : 54°

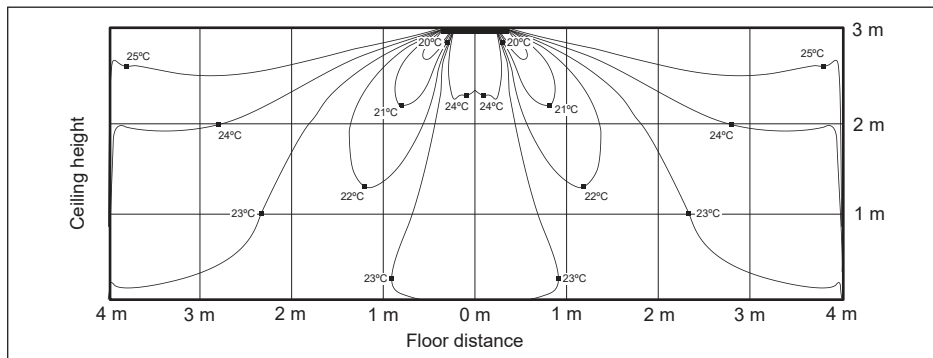

(3) Heating air velocity distribution

Discharge angle : 54°

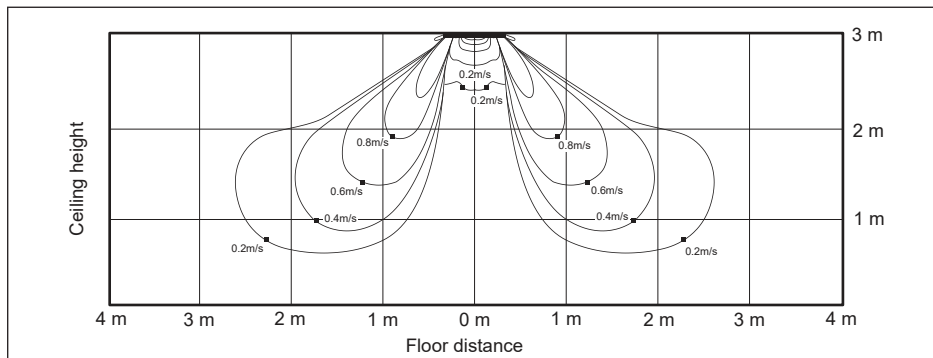

(4) Heating temperature distribution

Discharge angle : 54°

